



RHINO-RACK

Aerodynamic & Heavy Duty Roof Rack Systems

Rhino-Rack FOXWING Awning by OZTENT

Important: Please read these instructions carefully prior to installation. Please refer to your fitting instruction to ensure that the roof racks are installed in the correct locations. Check the contents of kit before commencing fitment and report any discrepancies. Place these instructions in the vehicle's glove box after installation is complete.

Layout

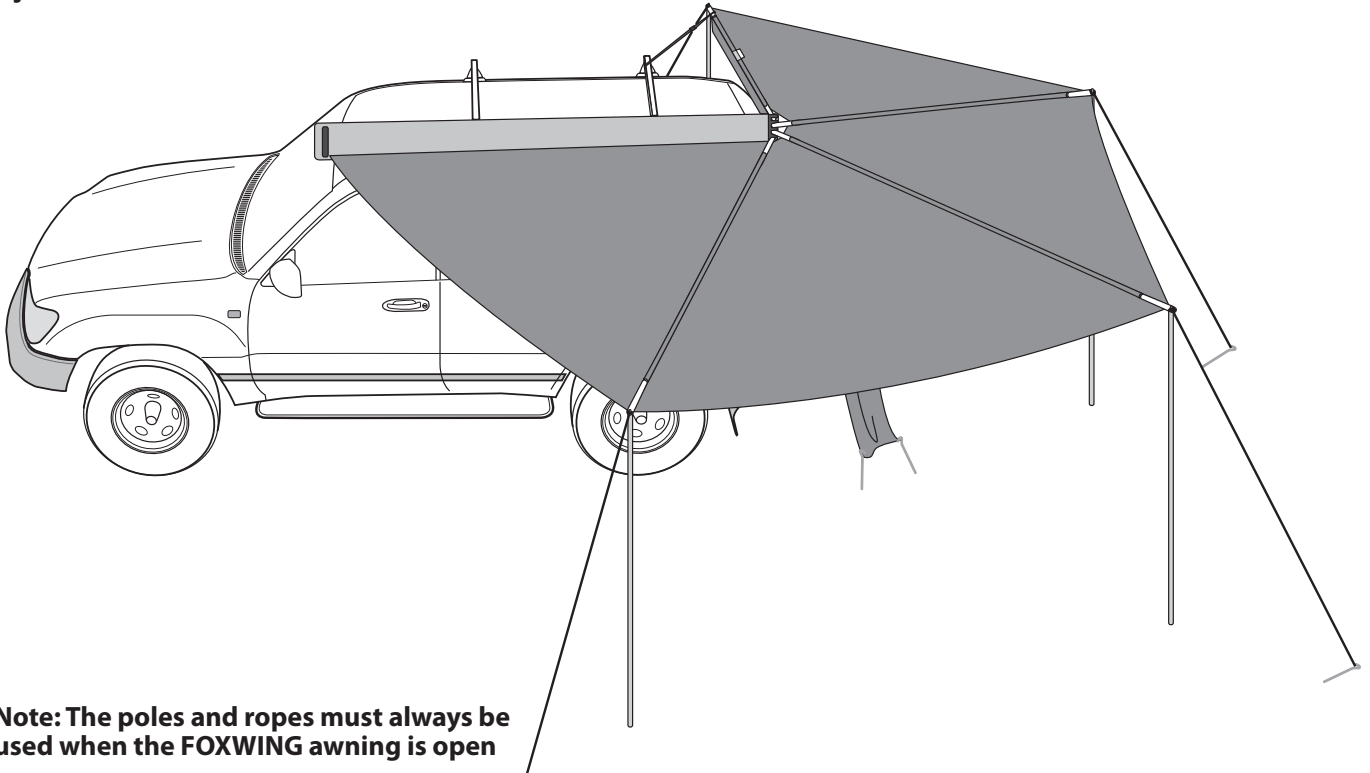

Note: The poles and ropes must always be used when the FOXWING awning is open

Important Information

Recommendations

It is essential that all bolt connections be checked after driving a short distance when you first install your Rhino FOXWING Awning. Bolt connections should be checked again at regular intervals (probably once a week is enough, depending on road conditions, usage, loads and distances travelled). You should also check the roof bars each time they are refitted.

Use only non-stretch fastening ropes or straps.

Please remove FOXWING Awning and crossbars when putting vehicle through an automatic car wash.

Load Ratings

With the addition of the FOXWING Awning, the load capacity of your crossbars will have to be adjusted accordingly. The FOXWING Awning and 2 crossbars weigh approximately 19kg. When roof racks are to be used in off-road conditions, please build a safety factor of 1.5 into this load limit. Although the roof racks are tested and approved to AS1235-2000, Australian road conditions can be much more rigorous.

Note for Dealers and Fitters

It is your responsibility to ensure that this fitting instruction is given to the end user or client.

Rhino-Rack
3 Pike Street, Rydalmere,
NSW 2116, Australia.
(Ph) (02) 9638 4744
(Fax) (02) 9638 4822

Document No: RR227
Prepared By: Andy Wana
Authorised By: Chris Murty

Issue No: 03
Issue Date: 13/02/2011

These instructions remain the property of Rhino-Rack Australia Pty Ltd and may not be used or changed for any other purpose than intended.



Rhino-Rack FOXWING Awning by OZTENT

Parts List

Item	Component Name	Qty
1	FOXWING Fold Out Awning	1
2	Crossbar Bracket	2
3	Crossbar Bracket Plate	2
4	M8 x 23mm T-Bolt	4
5	M8 X 17mm Flat Washer	6
6	M8 Nyloc Nut	6
7	Sportz / Aero Crossbar Insert	2
8	M8 X 25mm T-Bolt	2
9	M8 Spring Washer	2
10	M8 x 30mm Hex Bolt	2
11	Heavy Duty Crossbar Insert	2
12	M8 Channel Nut	2
13	Telescopic Support Pole	4
14	Metal Peg	10
15	Guy Rope	8
16	Tensioning Straps	1
17	Fitting Instruction	1

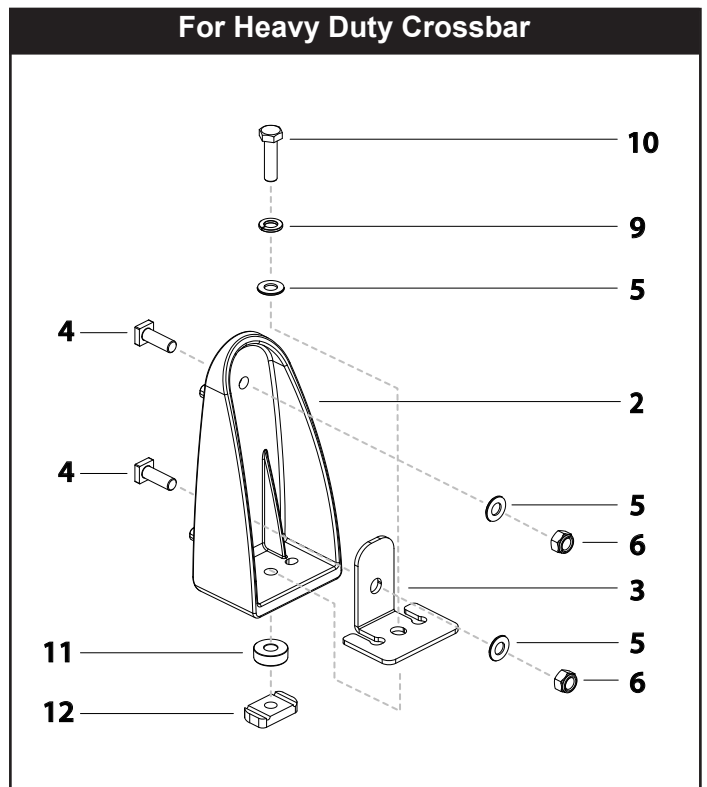
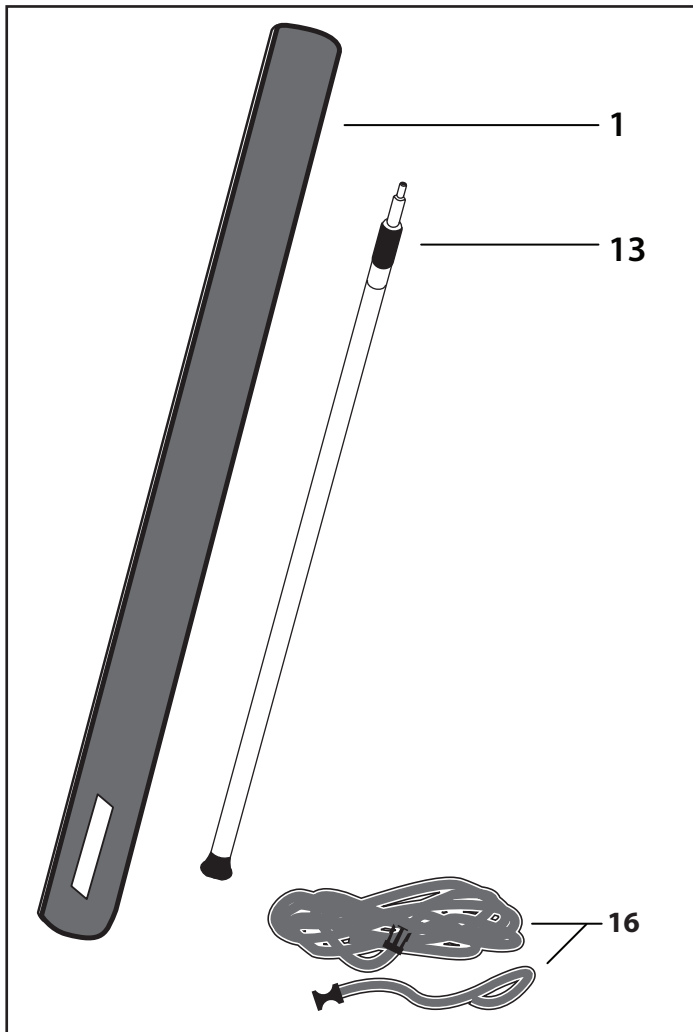
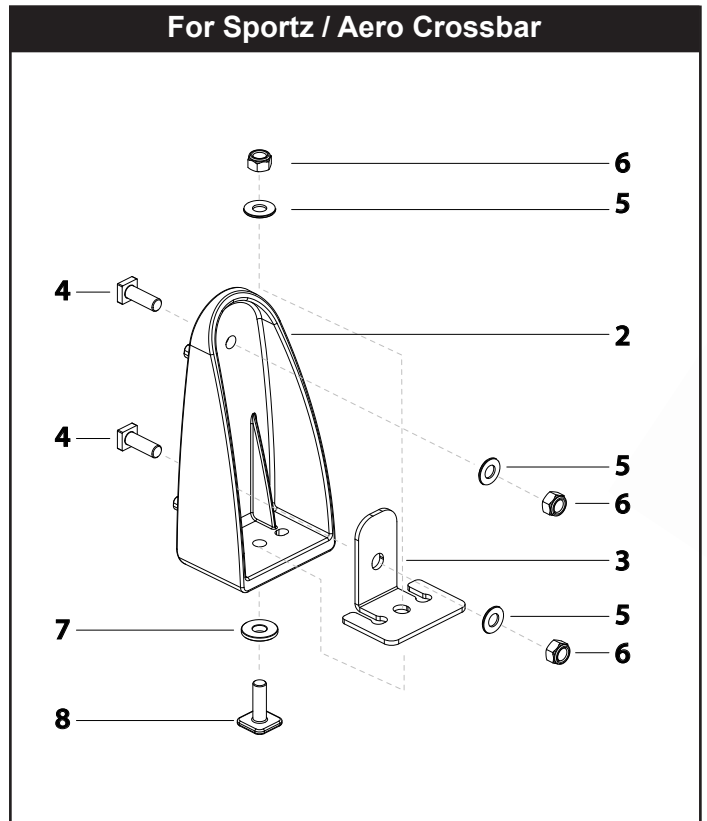

Tools Required:

Tape measure, 13mm spanner, 14mm spanner, Knife

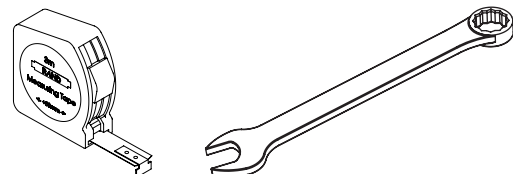

Care Instruction:

Wash and clean vehicle roof racks prior to fitment



Rhino-Rack FOXWING Awning by OZTENT

Minimum Crossbar Distance

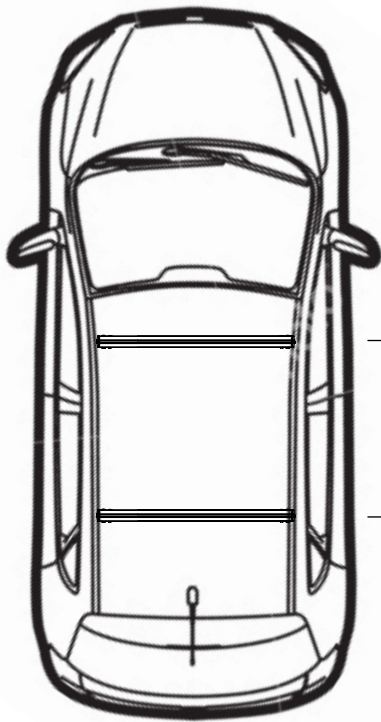

Distance measured from bar centre to bar centre

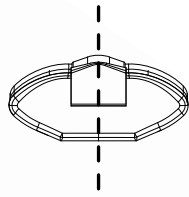

MINIMUM
800mm

Distance measured from bar centre to bar centre

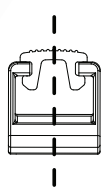

RHINO SPORTZ

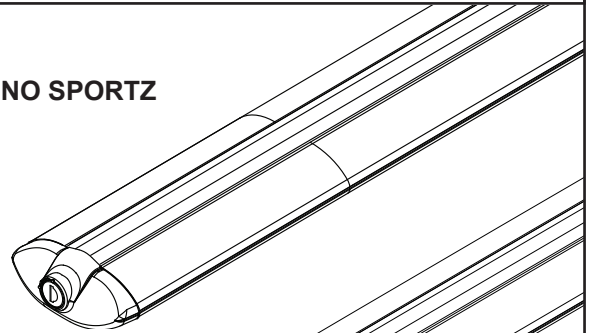

RHINO AERO

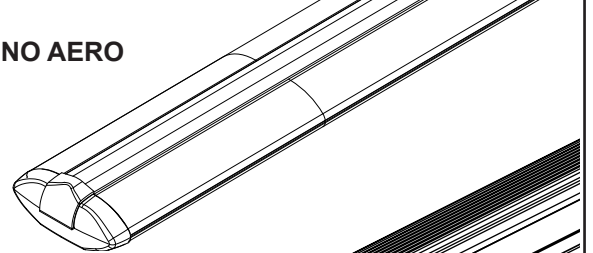

RHINO HEAVY DUTY



Fitting Instruction

1

When locating and inserting each T-bolt (A), ensure that you do not drop it into the recess.

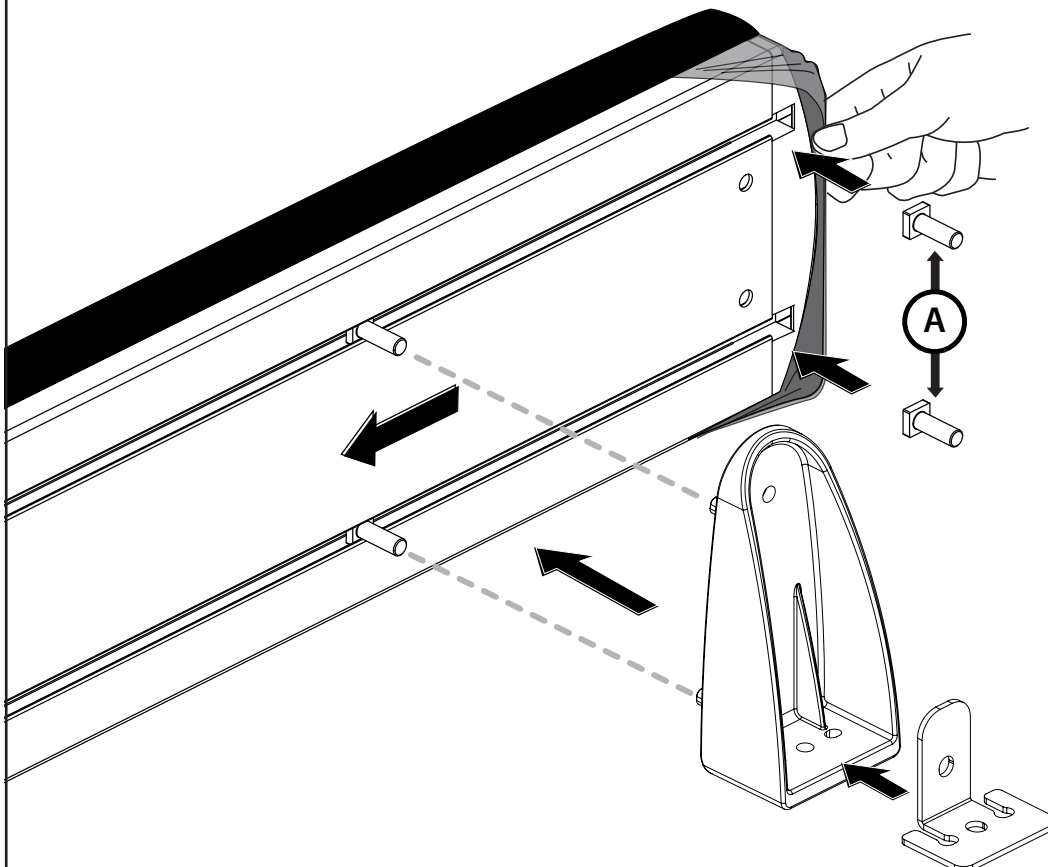



Rhino-Rack FOXWING Awning by OZTENT

2A For Sportz / Aero Crossbar

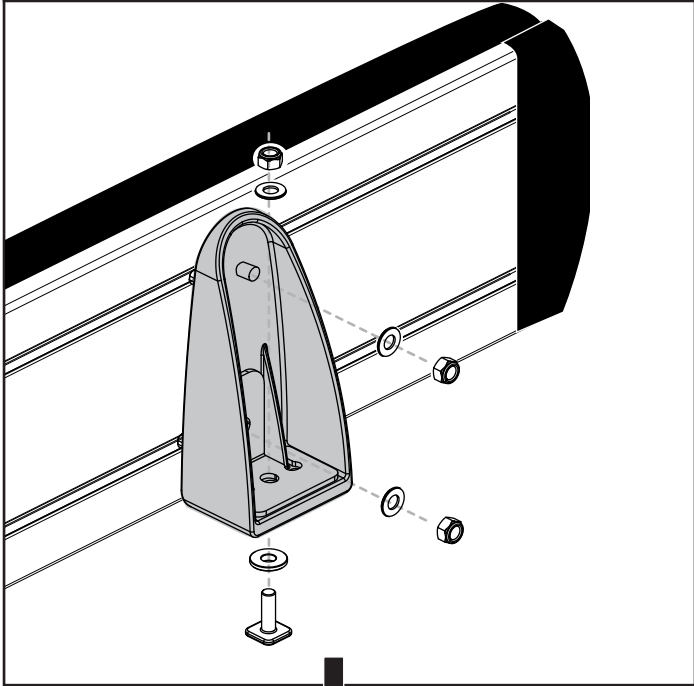

2B For Heavy Duty Crossbar

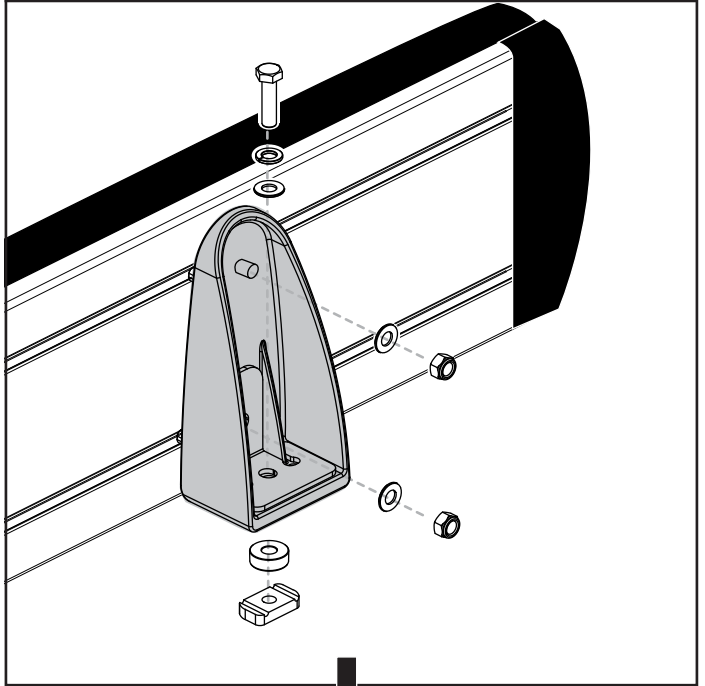

3A

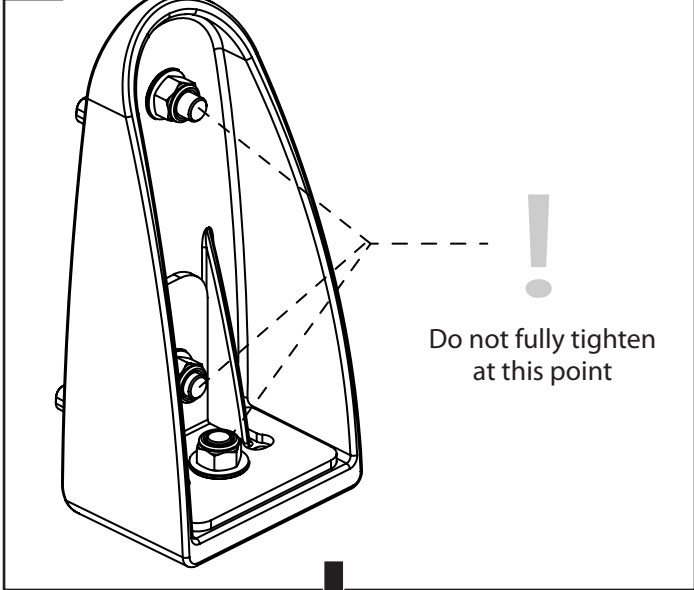

3B

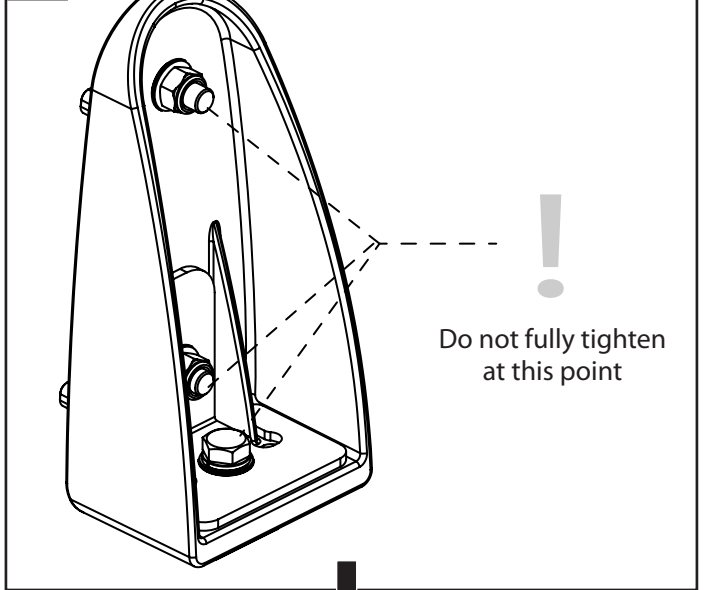

4A

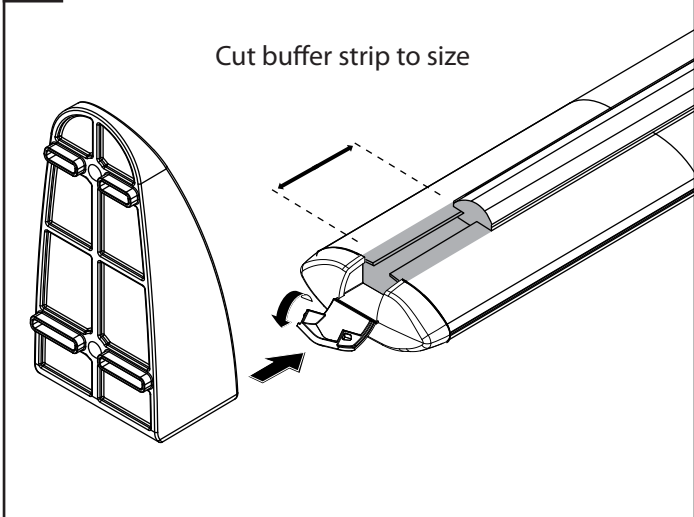

4B

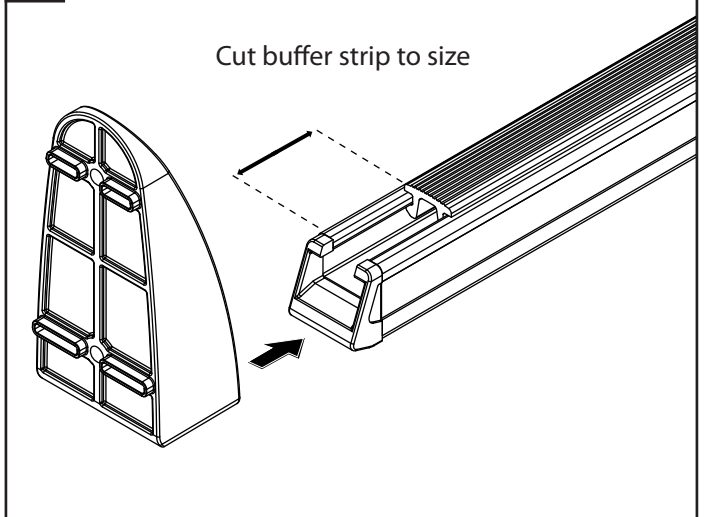



Rhino-Rack FOXWING Awning by OZTENT

5A Adjust the location of the crossbar bracket assembly to suit the crossbar distance on your vehicle

Side View

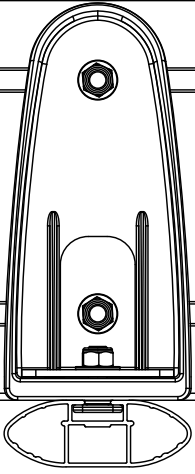

5B Adjust the location of the crossbar bracket assembly to suit the crossbar distance on your vehicle

Side View

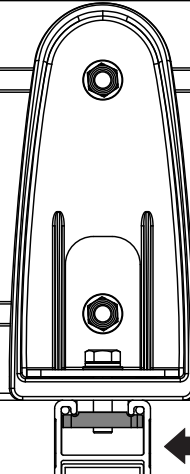

Channel nut must sit across the bar when tightened

6 Adjust the position of the FOXWING awning, paying extra attention to the rear overhang. Make sure that there is enough room to swing the awning open and it is free from obstruction (i.e. rear tail gate).

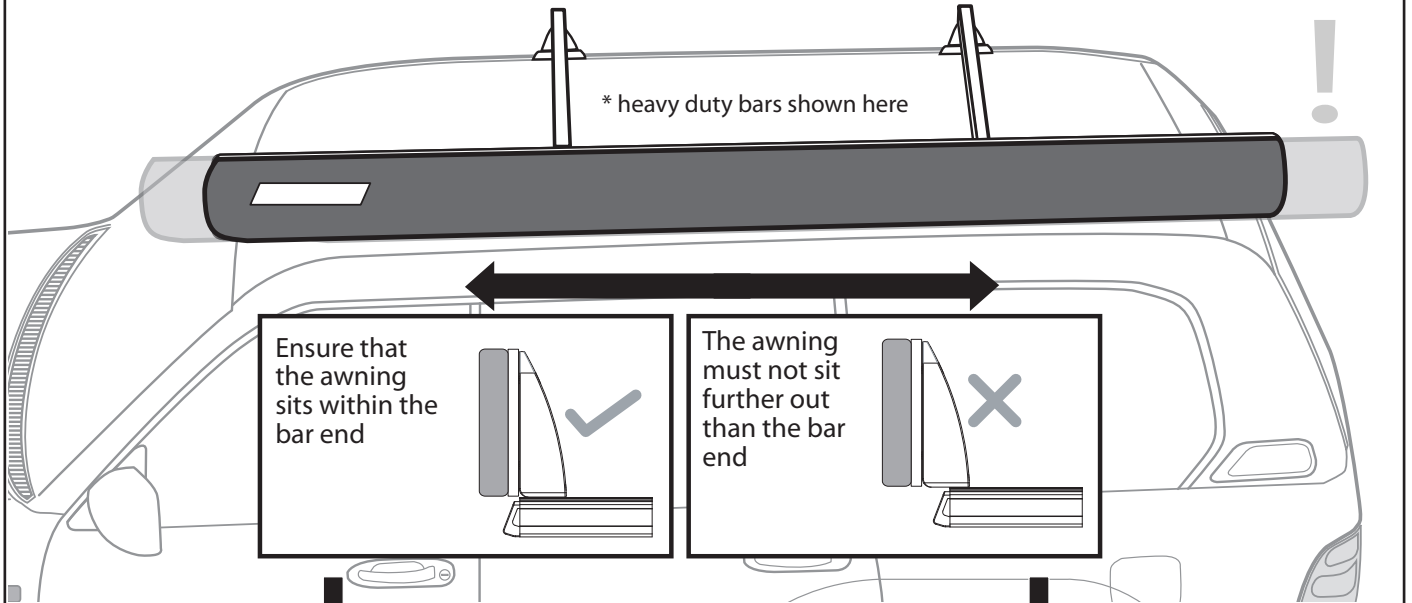

7A Tighten all nuts when done

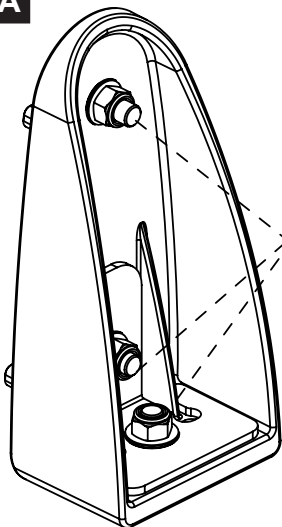

7B Tighten all nuts and bolt when done

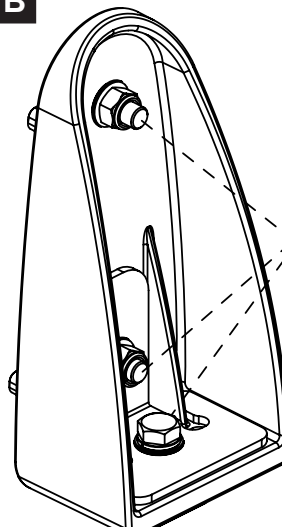



Rhino-Rack FOXWING Awning by OZTENT

Operation Instruction

1

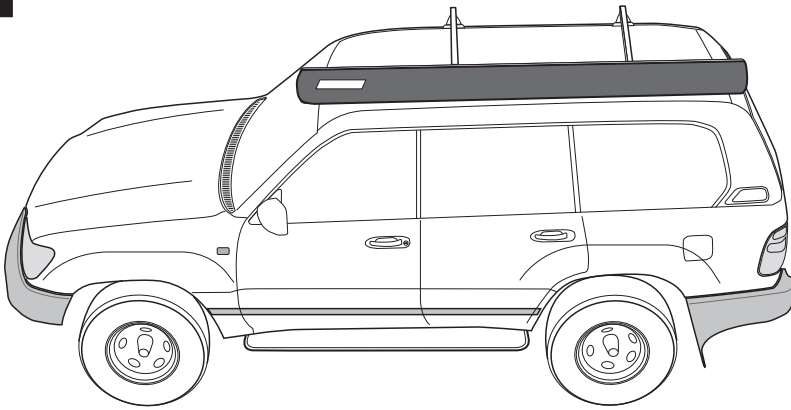

Note: Be careful in windy conditions, assistance from a second person is recommended. Refer to supplement.

2

Front of Car

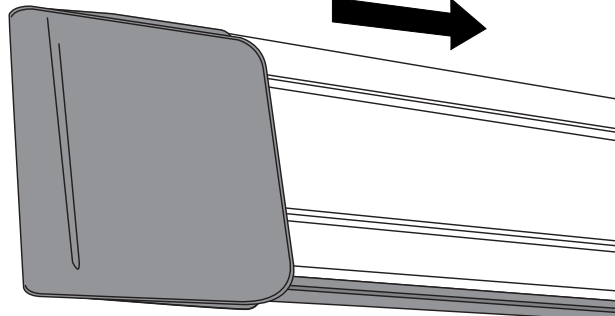

Open awning bag, see steps 3 - 5 for instructions on how to undo the velcro flaps.

3

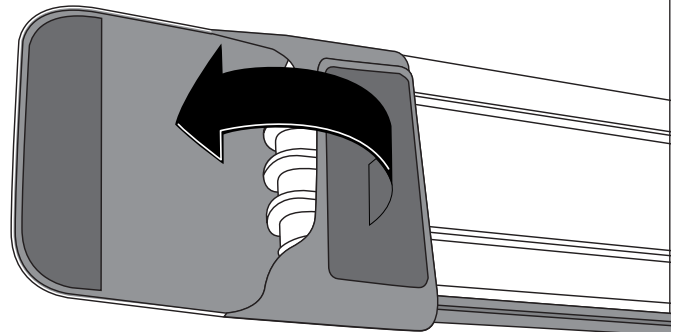

4

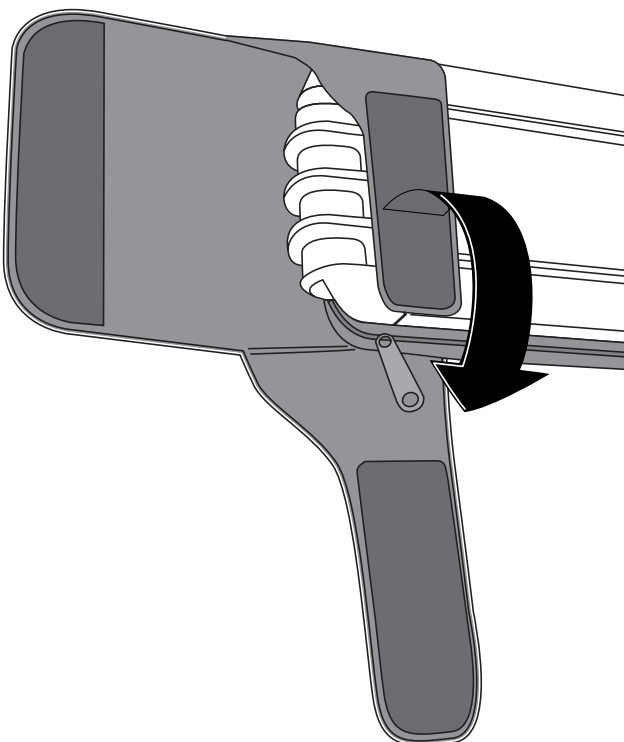

5

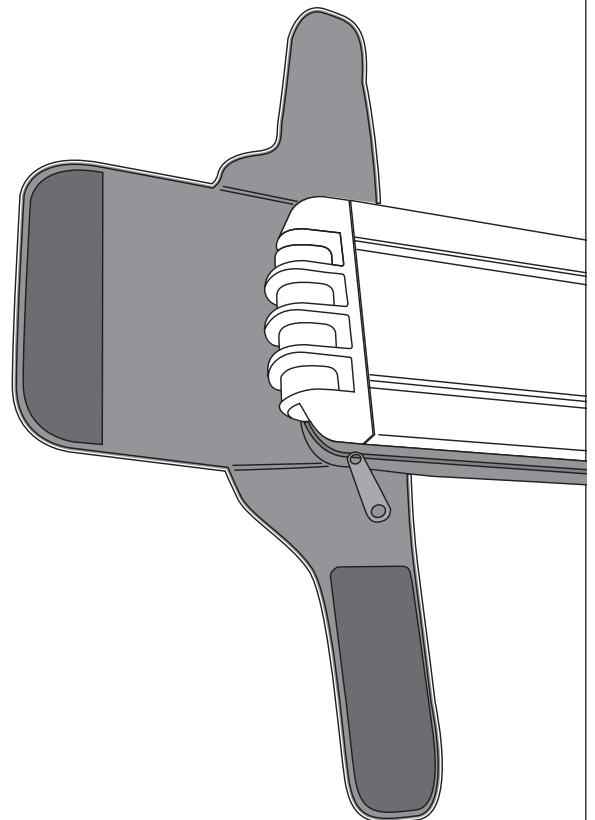



Rhino-Rack FOXWING Awning by OZTENT

6

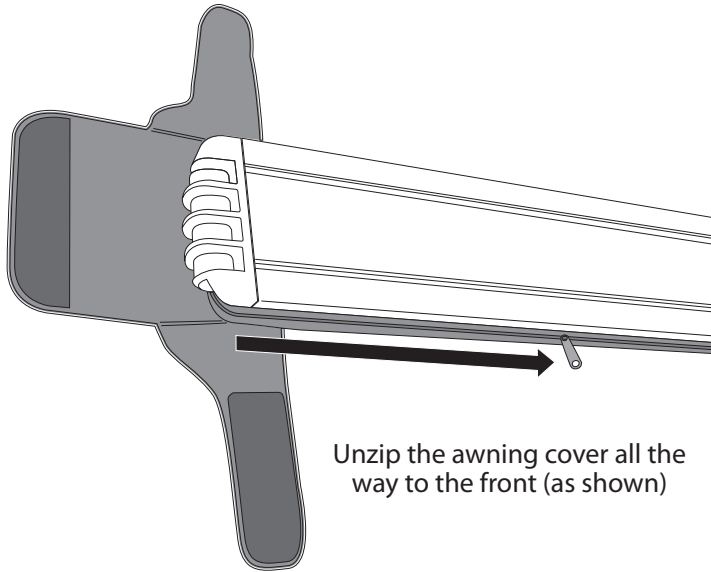

Unzip the awning cover all the way to the front (as shown)

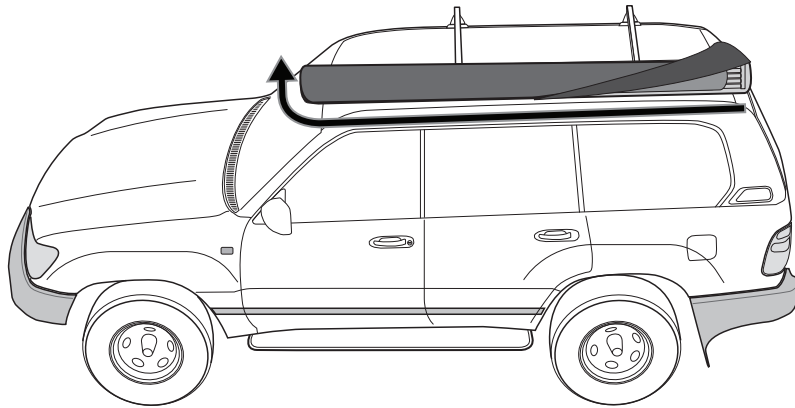

7

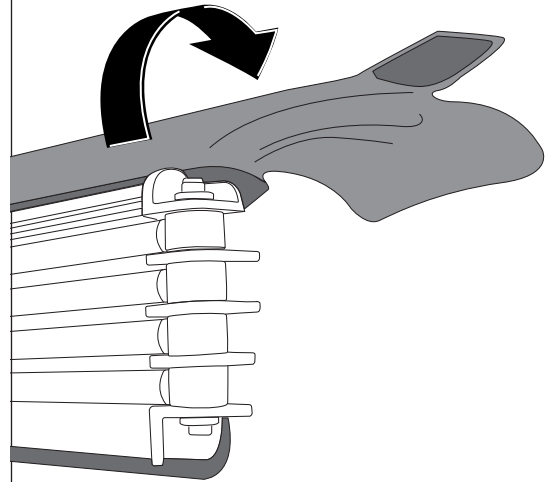

Peel the cover to the rear as shown. Make sure when opening the awning that the bag is clear of the hinge area

8

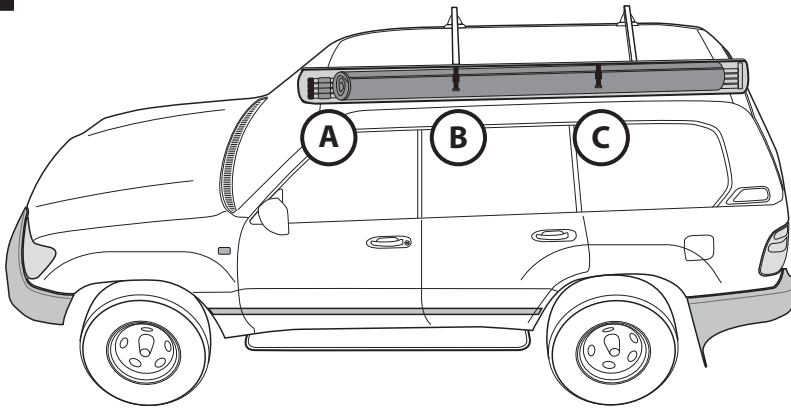

(A)



Undo the rubber latch at (A) and the 2 clips at (B) and (C)

9

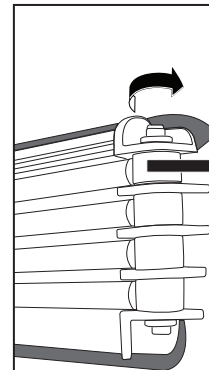
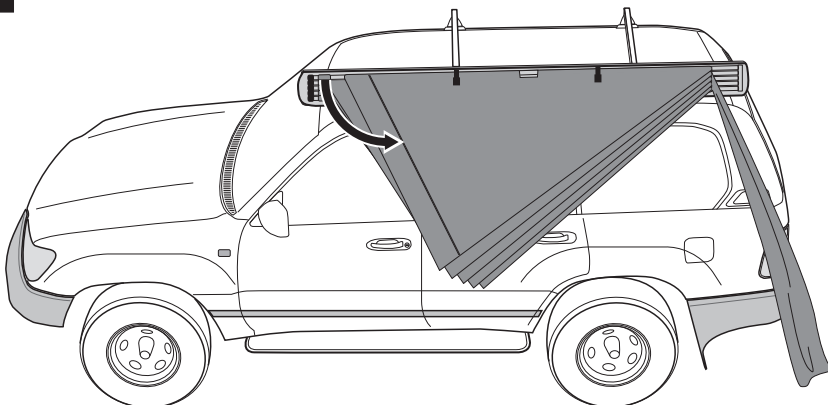

Start to open awning from the top pole.



Rhino-Rack FOXWING Awning by OZTENT

10

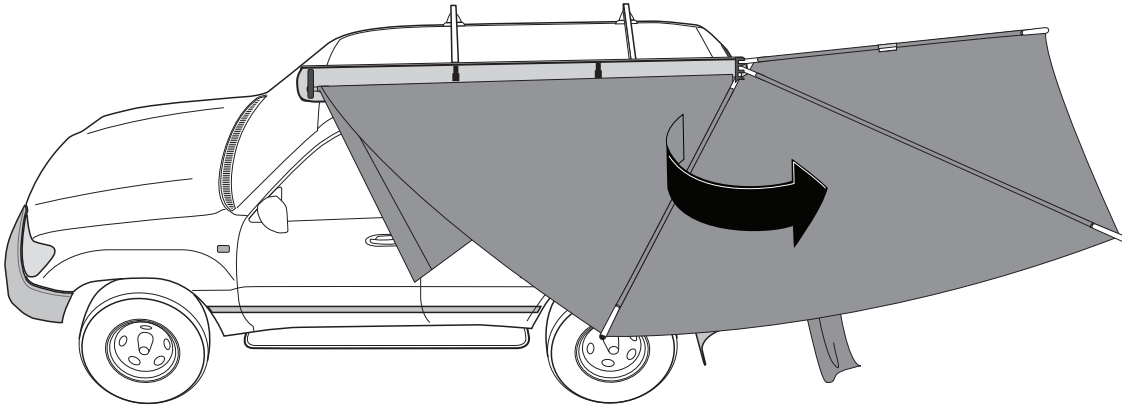

11

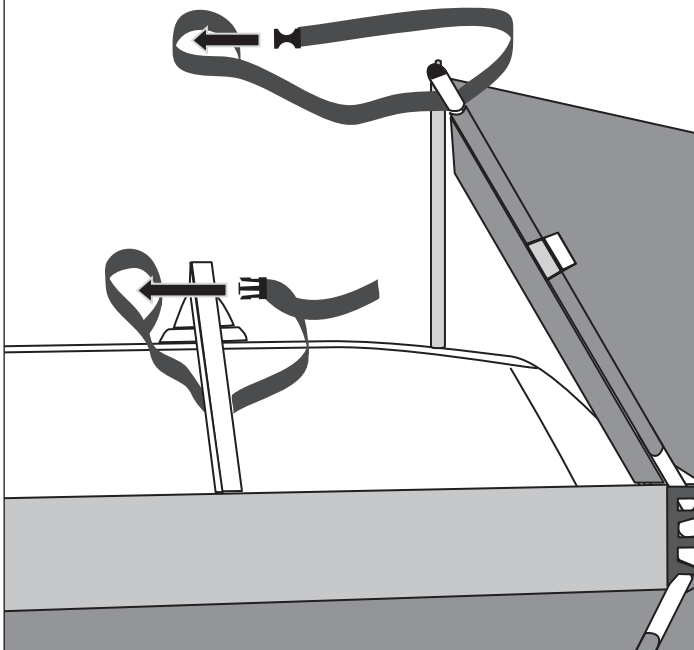

12

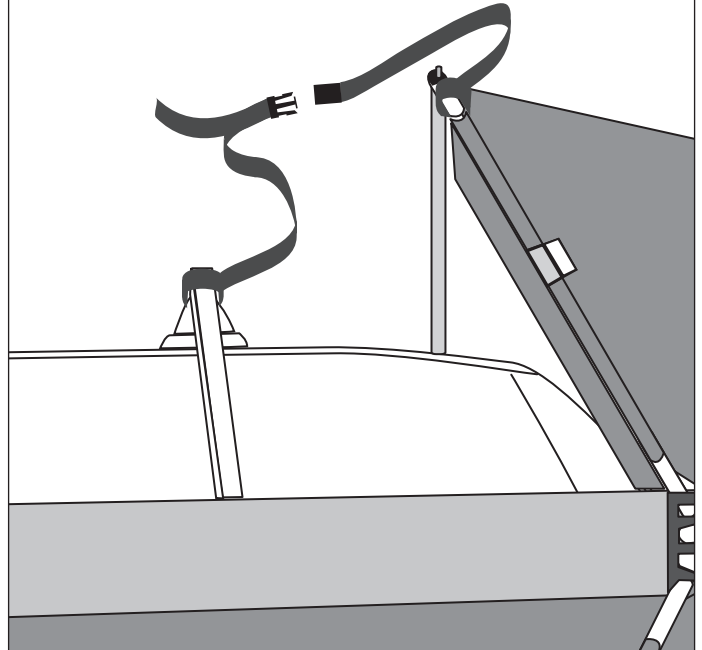

13

Secure the top pole onto the nearest crossbar. Pull the strap tightly (as shown) to maintain tension and shape of the awning.

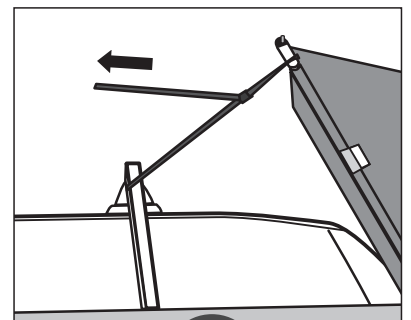
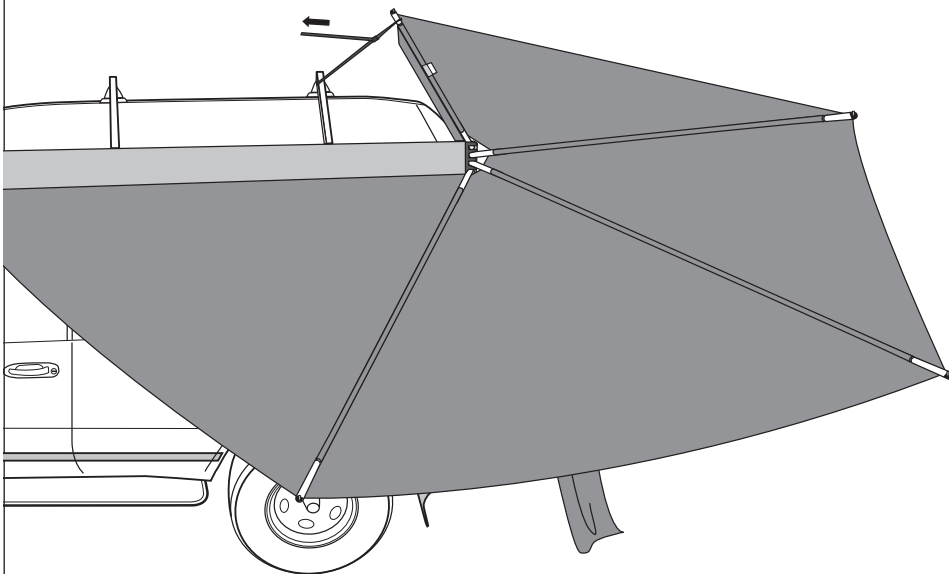

OR

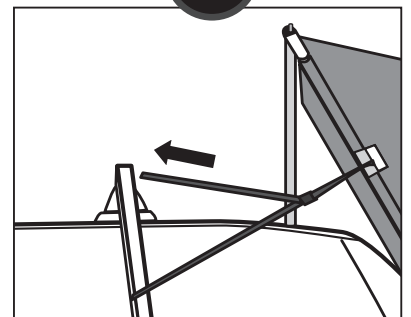



Rhino-Rack FOXWING Awning by OZTENT

14

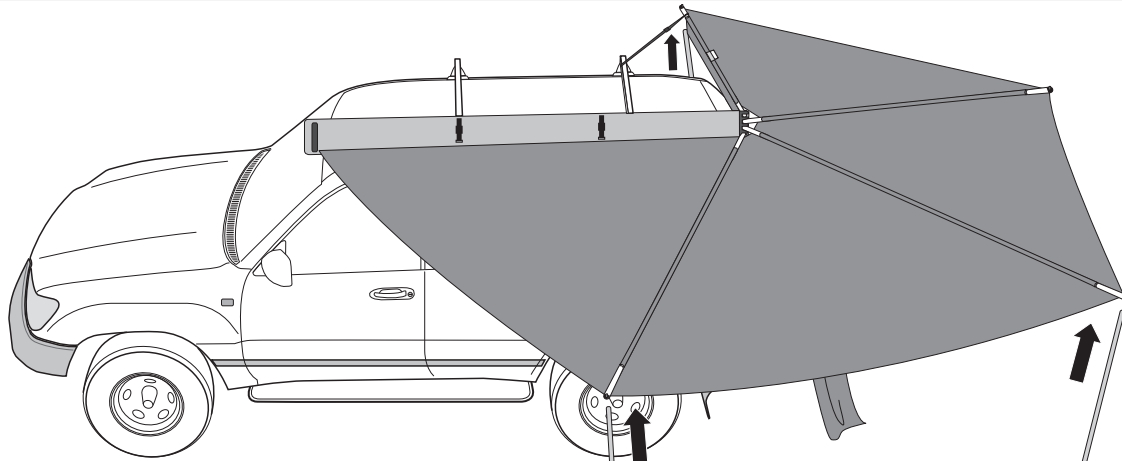

Insert the telescopic pole at each awning pole tip as shown

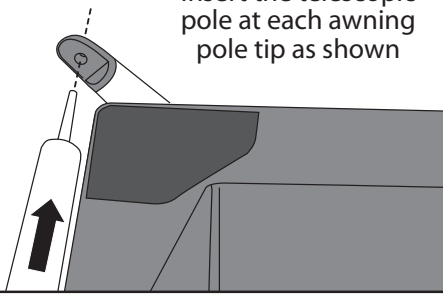

Secure each pole to the awning with the velcro straps

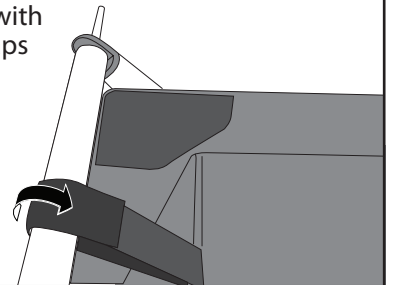

15

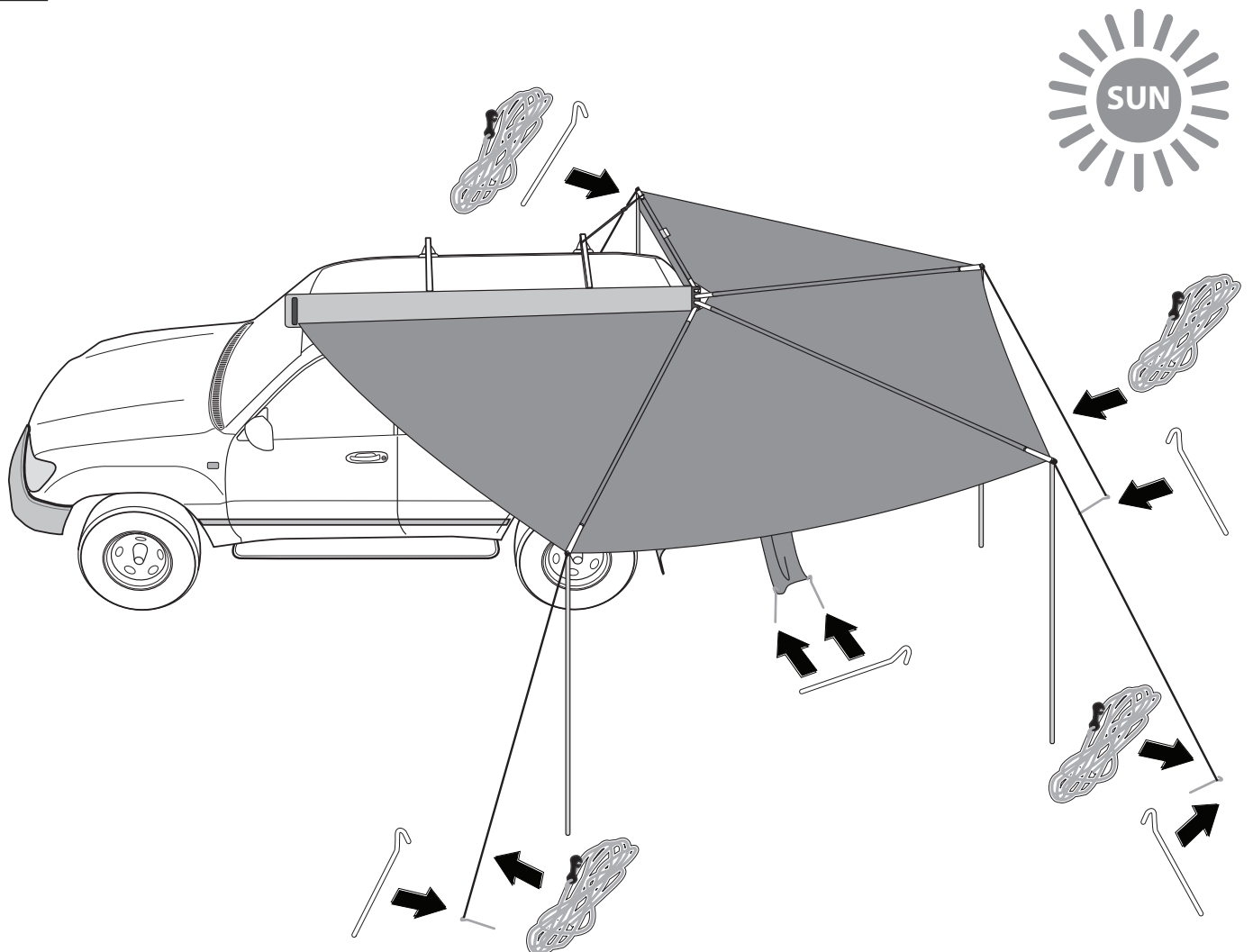



Rhino-Rack FOXWING Awning by OZTENT

16

Shorten the telescopic pole slightly

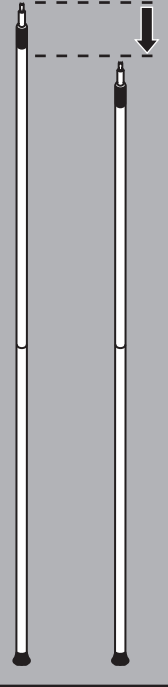

Secure the awning with the extra pegs and guy ropes as shown.

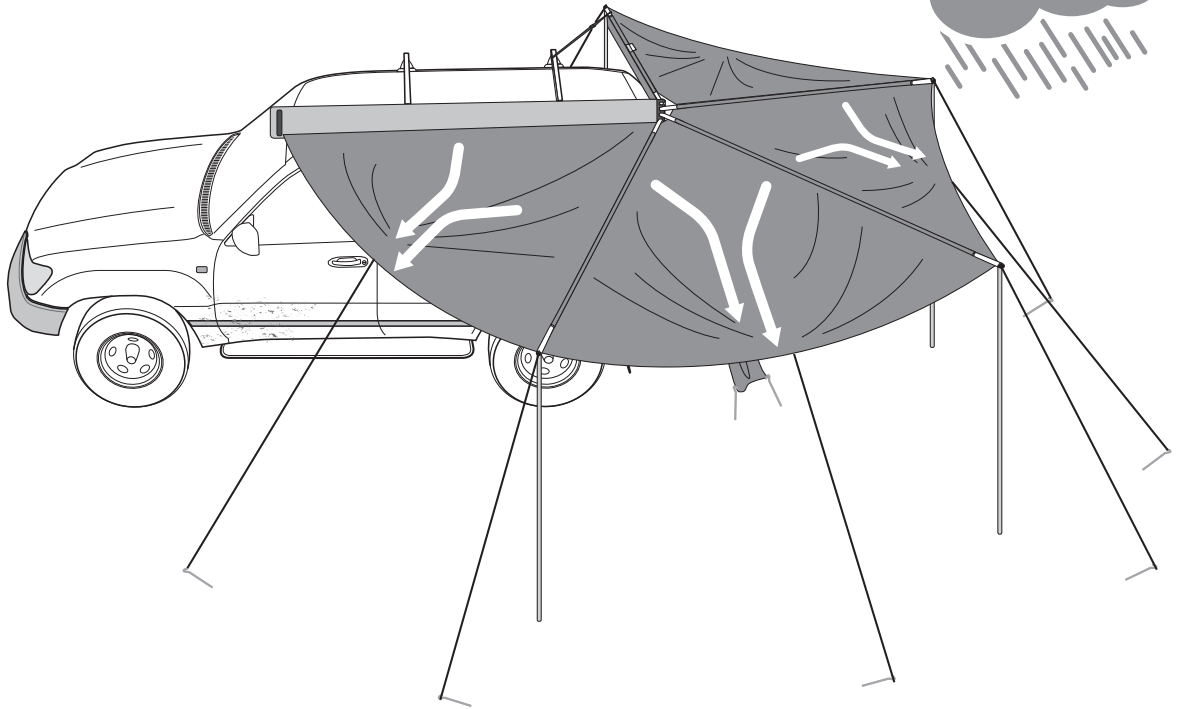

Storing Instruction

17

Undo the tensioning straps, the telescopic poles, guy ropes and pegs. Store these items in the supplied travel bags.

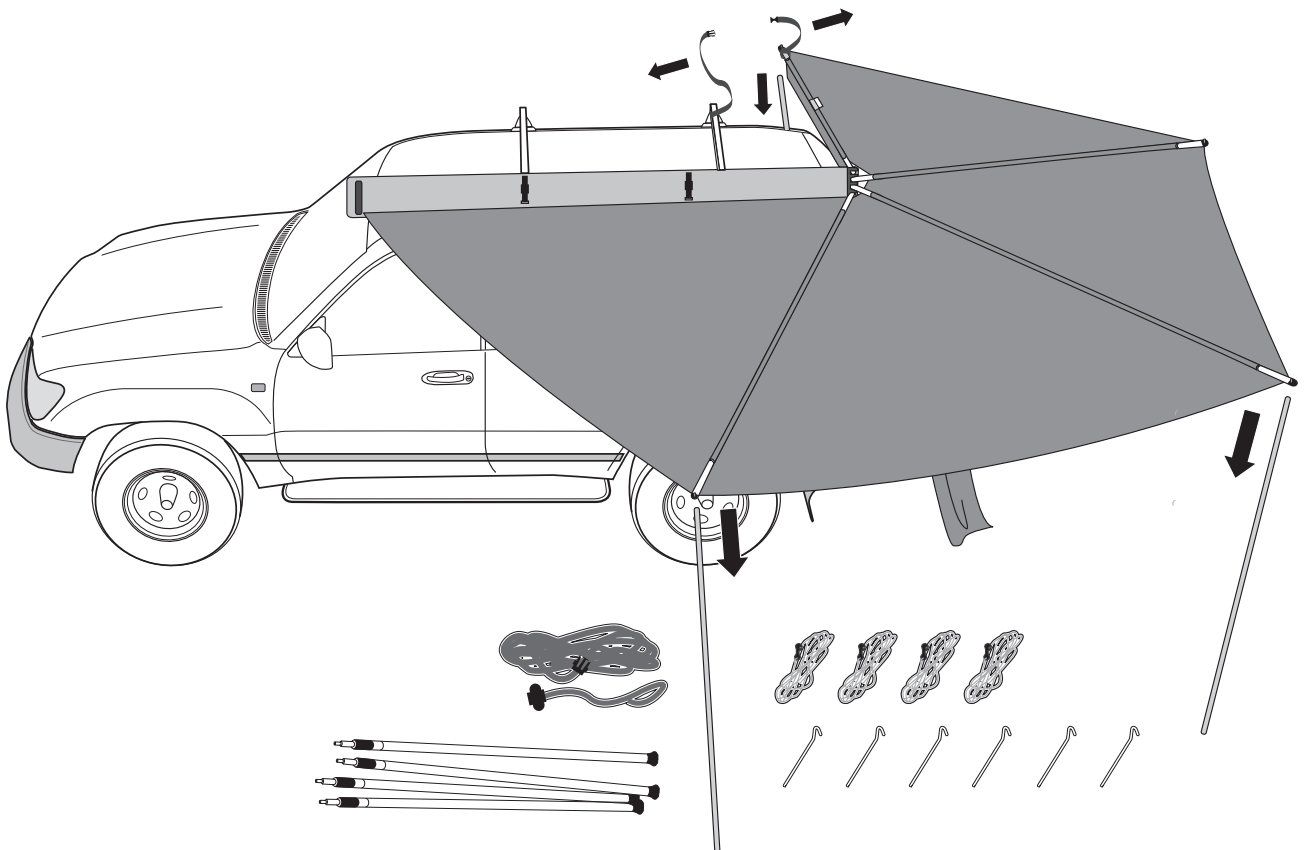



Rhino-Rack FOXWING Awning by OZTENT

- 18** Secure the poles with the rubber strap before rolling awning material up (see inset picture).

Fold the awning as shown on right.

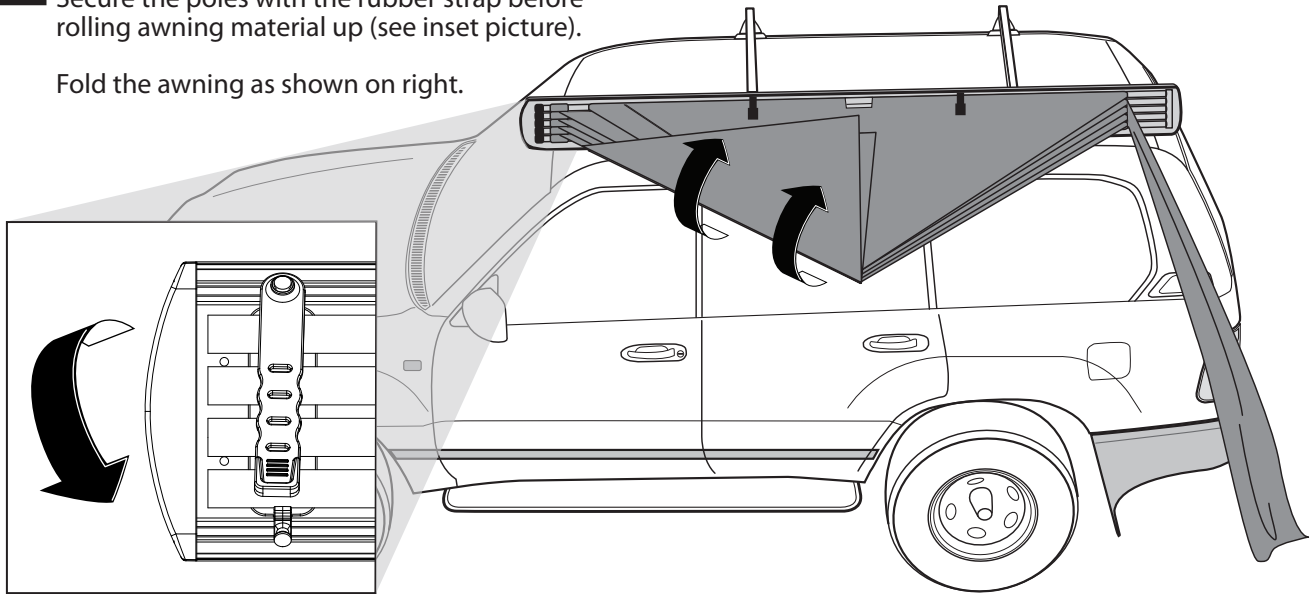

- 19** Roll the awning all the way up till you see the corresponding clips (A). Position the drain pipe (B) as shown. Clip awning into place.

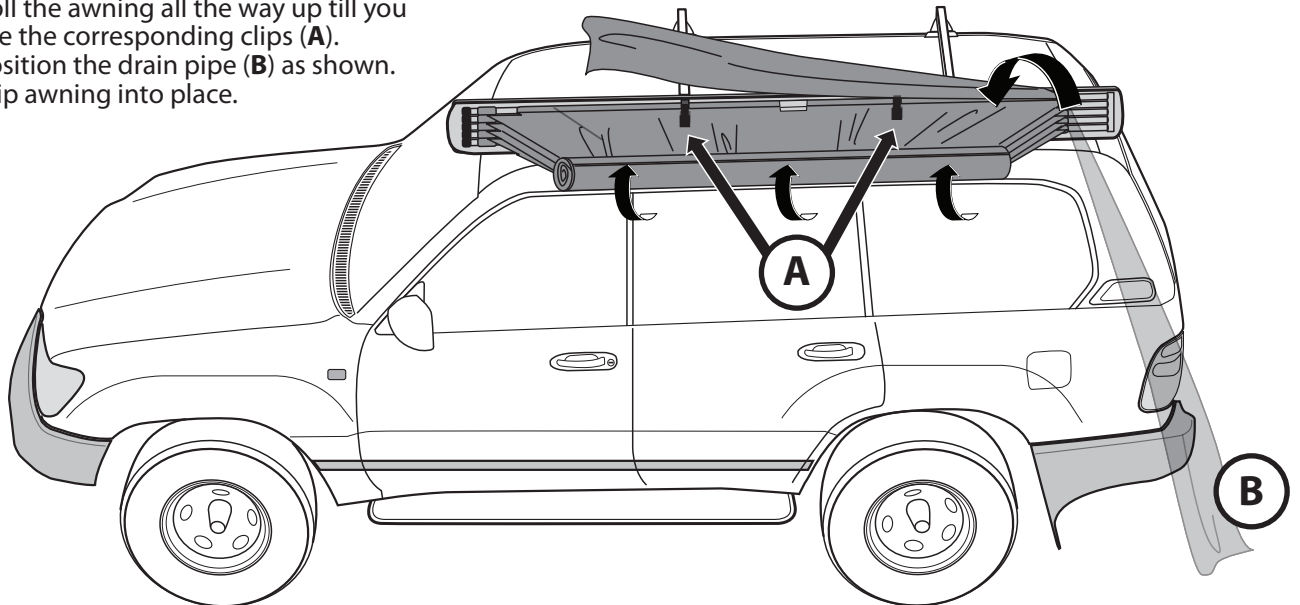

20

Tuck the excess awning by pushing it upwards as you pull the zip along the cover. This will prevent the awning from being caught up and damaged between the zipper.

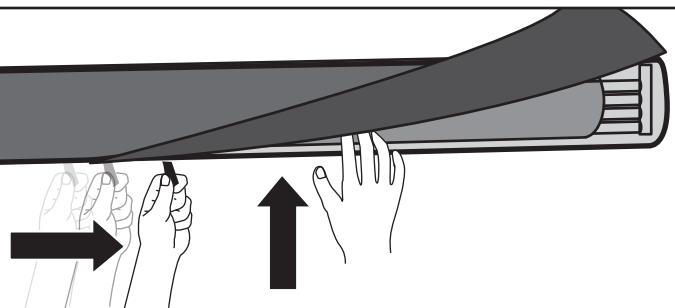

Secure the flaps so that the bag is fully enclosed (Refer steps 2 - 6).

