

**HILUX ARB WINCH/NON WINCH BUMPER, 2005 FLARE
MODEL ONWARDS
(SRS AIR BAG EQUIPPED MODELS)**

PRODUCT NUMBER: -

391 4110

FITTING KIT: -

617 2399

TOP TUBE AND BUFFERS

5100070: Top Tube Kit

5100020: Buffer Kit – With hole (required when fitting Top Tube)

5100030: Buffer Kit – With No Hole

WARNING

NOTE THE FOLLOWING: -



- ◆ This product must be installed exactly as per these instructions using only the hardware supplied.
- ◆ In the event of damage to any bull bar component, contact your nearest authorised ARB stockist. Repairs or modifications to the impact absorption system must not be attempted.
- ◆ Do not use this product for any vehicle make or model, other than those specified by ARB.
- ◆ Do not remove labels from this bull bar.
- ◆ This product or its fixing must not be modified in any way.
- ◆ The installation of this product may require the use of specialized tools and/or techniques
- ◆ It is recommended that this product is only installed by trained personnel
- ◆ These instructions are correct as at the publication date. ARB Corporation Ltd. cannot be held responsible for the impact of any changes subsequently made by the vehicle manufacturer
- ◆ During installation, it is the duty of the installer to check correct operation/clearances of all components
- ◆ Work safely at all times
- ◆ Unless otherwise instructed, tighten fasteners to specified torque

GENERAL CARE AND MAINTENANCE

By choosing an ARB Bar, you have bought a product that is one of the most sought after 4WD products in the world. Your bar is a properly engineered, reliable, quality accessory that represents excellent value. To keep your bar in original condition it is important to care and maintain it following these recommendations:

- Prior to exposure to the weather your bar should be treated to a Canuba based polish on all exposed surfaces. It is recommended that this is performed on a six monthly basis or following exposure to salt, mud, sand or other contaminants.
- As part of any Pre Trip Preparation, or on an annual basis, it is recommended that a thorough visual inspection of the bar is carried out, making sure that all bolts and other components are torqued to the correct specification. Also check that all wiring sheaths, connectors, and fittings are free of damage. Replace any components as necessary. This service can be performed by your local authorized ARB Stockist.

HAVE AVAILABLE THESE SAFETY ITEMS WHEN FITTING PRODUCT: -

Protective eyewear		Hearing protection	
--------------------	---	--------------------	---

NOTE: 'WARNING' notes in the fitting procedure relate to OHS situations, where to avoid a potentially hazardous situation it is suggested that protective safety gear be worn or a safe work procedure be employed. If these notes and warnings are not heeded, injury may result.

FASTENER TORQUE SETTINGS: -

SIZE	Torque Nm	Torque lb/ft
M6	9Nm	4lbft
M8	22Nm	16lbft
M10	44Nm	32lbft
M12	77Nm	57lbft

USE	PART No	QTY	DESCRIPTION
CONTROL BOX FITMENT (WINCH ONLY)	3756499	1	CONTROL BOX BRACKET
	6151234	2	BOLT, M8 x 1.25 x 25 LONG (BLACK)
	4581045	2	WASHER FLAT M8 (BLACK)
	6151132	2	NUT FLANGE M8
	EG50	2	GROMMET RUBBER
	180302	8	CABLE TIES
WINCH (8000/9000/9500 LB)	4581040	4	WASHER FLAT 3/8"
	6151074	2	BOLT UNC 3/8" x 1 3/4"
	BLB850	3	CABLE BLACK 850mm
IMPACT ABSORBER TO BULL BAR	6151304	4	NUT CAGE M10
	4581040	8	WASHER FLAT M10
	4581288	4	WASHER FLAT M10 (OVER-SIZED)
	4581048	8	WASHER, SPRING, M10
	6151232	8	BOLT, M10 x 1.5 x 30 LONG
	6151026	4	NUT, HEX, M10 x 1.5
BUFFERS TO BULL BAR (5100020 REQUIRED IF FITTING TOP TUBE)	3162469R	1	BUFFER (RH)
	3162469L	1	BUFFER (LH)
	6151128	12	NUT FLANGE M6
BUFFERS TO BULL BAR (5100030 REQUIRED IF NOT FITTING TOP TUBE)	3162466R	1	BUFFER (RH)
	3162466L	1	BUFFER (LH)
	6151128	12	NUT FLANGE M6
NUMBER PLATE TO BULL BAR INSERT TO BULL BAR	6821189	2	PLASTIC GROMMET
	6151384	2	SELF TAPPING SCREW BLACK
INDICATORS TO BAR	3163015	1	COMBINATION LIGHT SURROUND KIT
	6821151L	1	INDICATOR KIT, LHS
	6821152R	2	WIRING LOOM
WING TRIM FITMENT	3163001R	1	TRIM, WING (LH), HILUX 05
	3163001L	1	TRIM, WING (RH), HILUX 05
	4581082	10	WASHER, FLAT, M6 (BLACK, 20 OD)
	6151162	10	NUT, NYLOC, M6x1
IMPACT ABSORBER TO CHASSIS	3756721	1	BRKT, CHASSIS MOUNT, HILUX 05
	4581040	4	WASHER, FLAT, M10
	4581048	4	WASHER, SPRING, M10
	6151133	4	NUT, M10 x 1.25
CHASSIS STIFFENING PLATE TO CHASSIS & IMPACT ABSORBER	3199756R	1	PLATE (RH), CHASSIS, HILUX 05
	3199756L	1	PLATE (LH), CHASSIS, HILUX 05
	6151234	2	BOLT, M8 x 1.25 x 25 LONG (BLACK)
	6151088	6	BOLT, M10 x 1.25 x 35 LONG
	4581040	12	WASHER, FLAT, M10
	4581045	2	WASHER, FLAT, M8 (BLACK)
	4581048	6	WASHER, SPRING, M10
	4581047	2	WASHER, SPRING, M8 (BLACK)
	6151133	6	NUT, M10 x 1.25
LOWER GRILL BRACKET	3757525	1	BRKT GRILL MNT HILUX 05
	6151234	2	BOLT, M8 x 1.25 x 25 LONG (BLACK)
	4581045	2	WASHER, FLAT, M8 (BLACK)
	4581047	2	WASHER, SPRING, M8 (BLACK)
	6151132	2	NUT FLANGE M8

CENTRE STONE DEFLECTORS	6522649	1	PANEL STONE GUARD UPPER HILUX 05
	6522650	1	PANEL STONE GUARD LOWER HILUX 05
	6151303	4	CAGE NUT, M8 (3mm PLATE)
	6151301	4	CAGE NUT, M8 (4mm PLATE)
	4581045	8	WASHER, FLAT, M8 (BLACK)
	4581047	8	WASHER, SPRING, M8 (BLACK)
	6151234	8	BOLT, M8 x 1.25 x 25 LONG (BLACK)
WING STONE DEFLECTORS	6522651R	1	PANEL, WING (RH), HILUX 05
	6522651L	1	PANEL, WING (LH), HILUX 05
	6151315	10	CAGE NUT, M6 (1.6mm PLATE)
	4581082	10	WASHER, FLAT, M6 (BLACK, 20 OD)
	4581287	10	WASHER, SPRING, M6 (BLACK)
	6151213	10	BOLT, M6 x 1.0 x 20 (BLACK)
	6151094	2	BOLT M12 x 1.25 x 30 LONG
	4581049	2	WASHER, FLAT M12
	4581050	2	WASHER, SPRING M12
180302	4	CABLE TIES	
TOP TUBE TO BULL BAR (5100070)	613 1371	1	TOP TUBE ASSEMBLY
	6151255	2	BOLT M12 x 1.75 x 40 mm LONG
	4581049	2	WASHER M12 FLAT
	4581050	2	WASHER M12 SPRING
WINCH COVER PANEL	6522661	1	PANEL WINCH COVER
	6151256	2	BUTTON HEAD SCREW M6 x 16 mm
	6151046	2	WASHER FLAT M6
	6151128	2	WASHER FLAT M6
	6191005	1	WINCH COVER EXTRUSION
AERIAL PLUGS	3162152	2	CB AERIAL CAP

**OPTIONAL LIGHT SETS TO SUIT THIS PRODUCT:
ARB 6821201 Fog light kit to suit 3163015**

Up to IPF 900 series fog or driving light sets

Tools required: -

10mm drill bit and drill, 5mm drill bit and drill, Satin black spray can, scissors, ruler, basic spanner & screw driver set, stepped ring spanner to suit 3/8" bolt.

ASSEMBLY SEQUENCE FOR BULL BAR INSTALLATION.

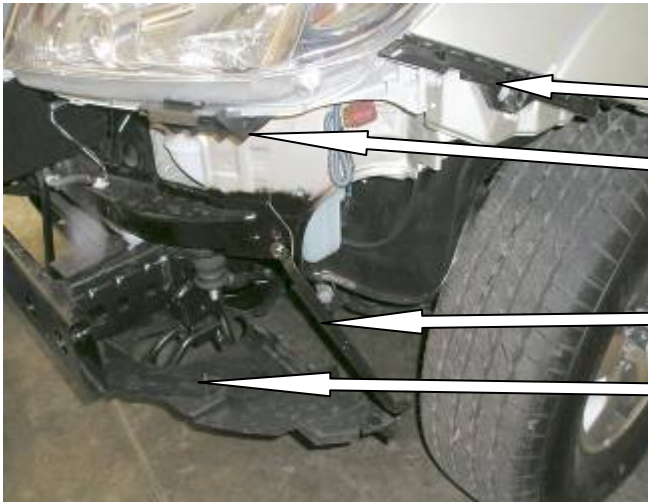

1. Remove existing bumper and grill from the vehicle.

Once these are removed:

- Remove plastic fittings attached to the fender and discard
- Remove the light bracket fitting and discard, this is done by first removing the light and then unscrewing the bracket from the rear of the light fitting.
- Remove the bumper braces and discard.
- Remove the chassis cross-brace and discard.



2. Remove the vehicles headlights.

3. Carefully read the wiring diagram supplied at the end of these instructions.

4. Take the relay loom (6821198) from the kit and position in the engine bay so that all wires will reach the appropriate connections.

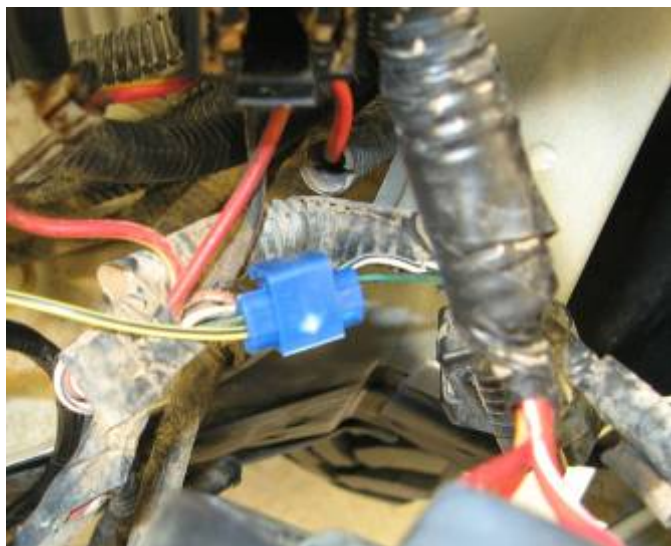

5. Starting with the passenger side, use scotch locks to connect the red wire from the indicator loom (6821152) to the green wire from the vehicles front park lamp.

6. Connect the Yellow / Black wire from the relay loom to the Green / Black wire from the vehicles left indicator.

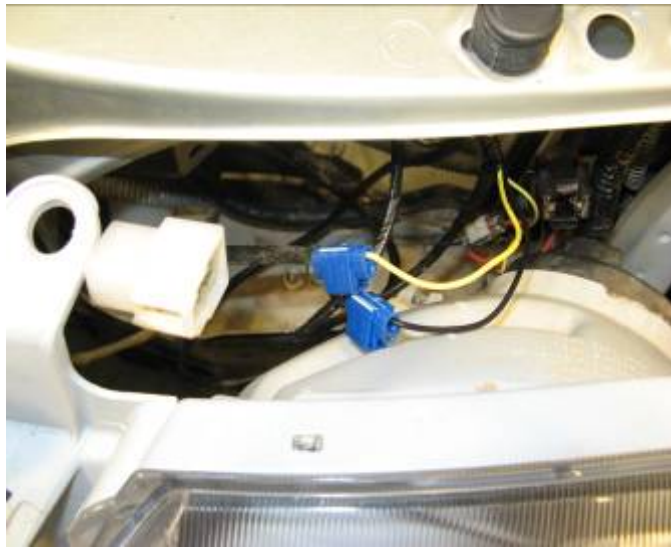

7. Connect the Yellow and Black wires from the relay loom to the Green and Black wires from the indicator loom.
8. Let the indicator loom hang freely for connecting to the bull bar indicators later on.
9. Do the same for the drivers side using the wiring diagram supplied as a reference for the correct wire colors.

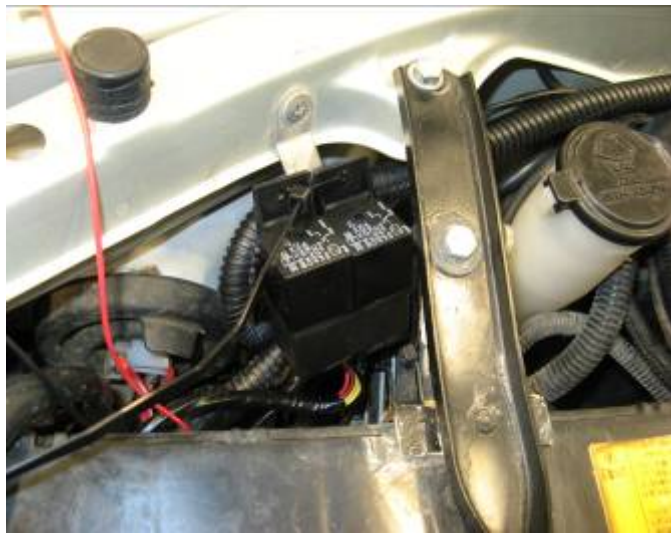

10. Find a suitable place and mount the relay.
- NOTE: Always mount the relay upright to help prevent water ingress.



11. Run the main black wire to a suitable earth.
12. Connect the main power wire (red) to the positive terminal of the battery. (Main battery if a dual battery system is installed)

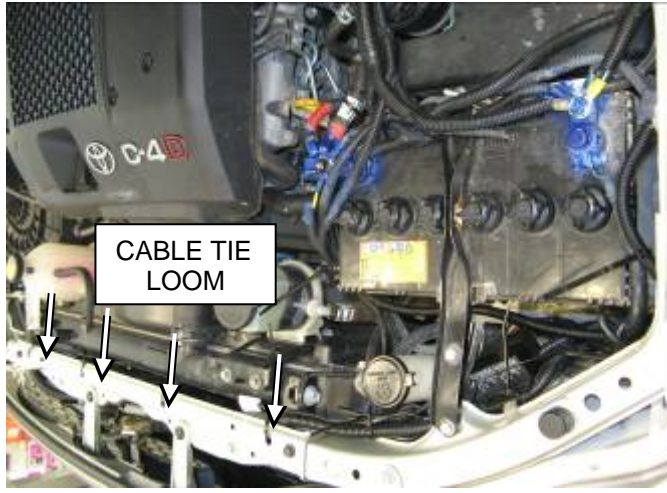

13. Using the cable ties supplied, secure the loom being sure as to keep clear of any hot, sharp or moving surfaces.

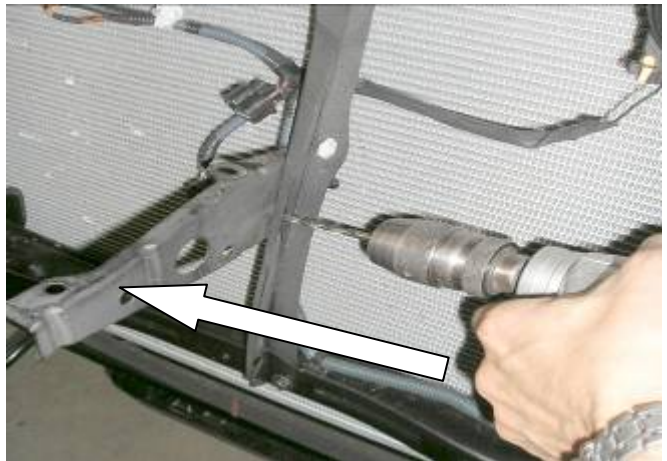

14. Remove the protruding bracket in front of the radiator, as it is no longer required (note: the vertical member of this bracket must not be removed as it holds the bonnet latch in position). This may be done by either drilling out the existing spot-welds with a 5mm drill as shown, or by cutting it off with a grinder. Re - locate the air temp sender (if fitted) to one of the hole in the vertical bracket.

Paint exposed metal to prevent rusting.

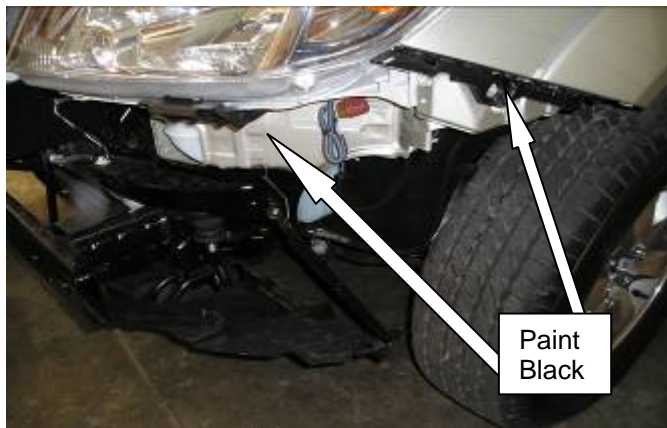

15. Spray paint the metal under side of the fender and the under side of the headlamp black.

Ensure the area to be painted is well masked to ensure no over spray on other components.



16. Fit buffers to bar using the 6mm flange nuts.

(DO NOT OVER TIGHTEN)

FOR WINCH BUMPER BARS, FIT BUFFER WITHOUT ANY HOLE IN IT.

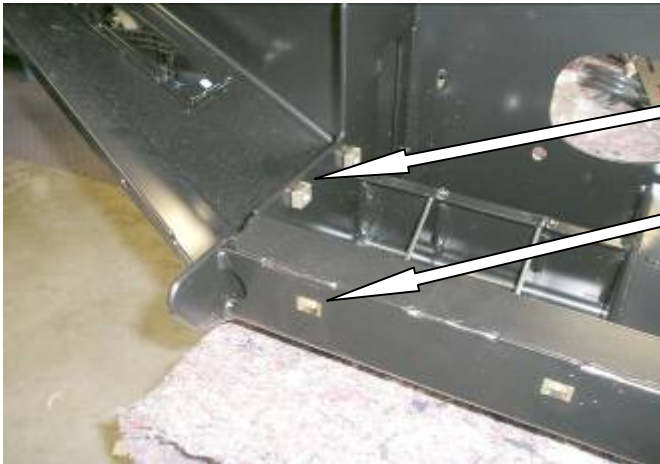

17. Fit cage nuts and nylon plugs to the bull-bar.

M10 cage nuts. (4 off) Caged portion is to centre of bull bar.

M8 cages nuts. (4 off) Caged portion is to top of bull bar.

M6 cages nut (2 off) front face of top pan. Caged portion faces lower portion on the bar. (Not shown in the photo graph)

Make sure the M8 cage nuts that suite 3mm plate is used, as there are also cage nuts in this kit suitable for 4mm plate, which are used later. Similarly, make sure the M6 cage nut suite 3mm plate.

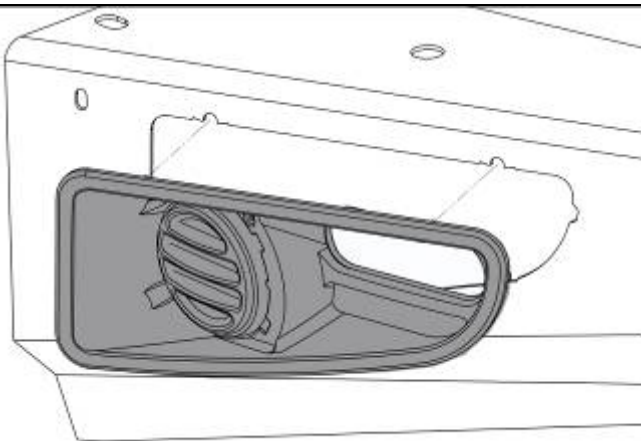

18. Assemble and install combination light surrounds (p/n 3163015) as per instructions no. 3786421 supplied with surround kit. Note: Optional fog lamps can be installed at this point as per fitting instruction no. 3783315 supplied with fog lamp kit no. 6821201. Wire the combination lamp to the vehicles indicator and clearance lamps.

Caution: Cable tie all cables together and keep all cables clear of sharp edges and moving parts.



19. Loosely fit the wing trims using the oversized M6 washers and the M6 nyloc nuts. These nuts will be tightened after the bar has been fitted to the vehicle and the wing trims have been positioned in an optimal position.

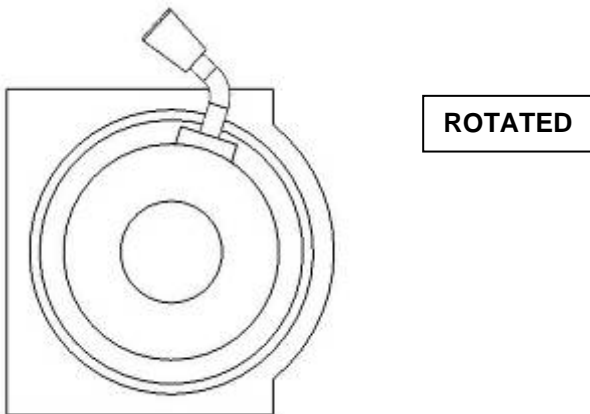
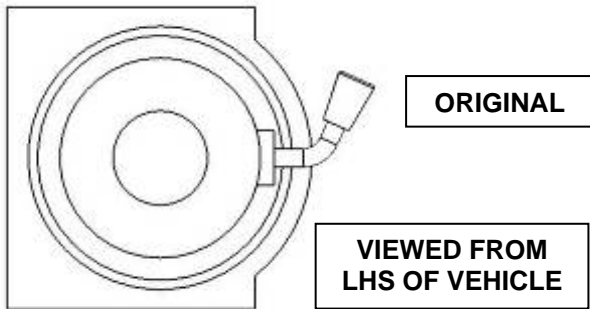

TO FIT A WINCH BAR

(If not fitting a winch proceed to step 43)

20. To fit an 8/9/9.5/000lb winch, rotate gearbox 72° counterclockwise.

21. Stand winch upright and undo the capped head screws and by lifting the gearbox only a couple of millimeters, rotate the gearbox. Once in position, refit all screws and tighten firmly.

WARNING: Do not lift gearbox more than a couple of millimeters.



22. Remove the cover from the control box.

23. Replace the three main power cables that go from winch to control box. Make sure that you identify the colour codes on the new cables before closing control box cover.

24. This must be done for whatever winch is to be fitted to the bull bar.

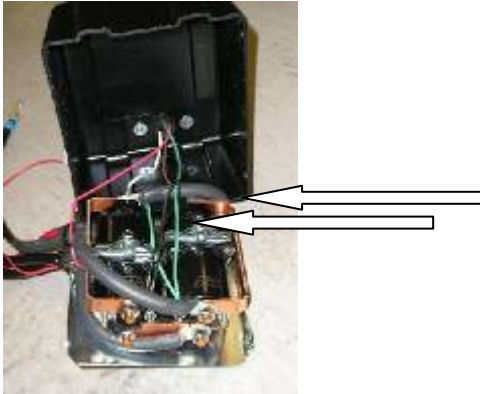

25. If fitting the XP 9.5 **winch**, remove the cover from the control box, otherwise proceed to step 33.

26. Remove the two cap screws, nuts and spacer washers that hold the four solenoids in place.



27. Remove the four solenoids from the base of the control box using the copper bus bar as an aid and hold to one side.

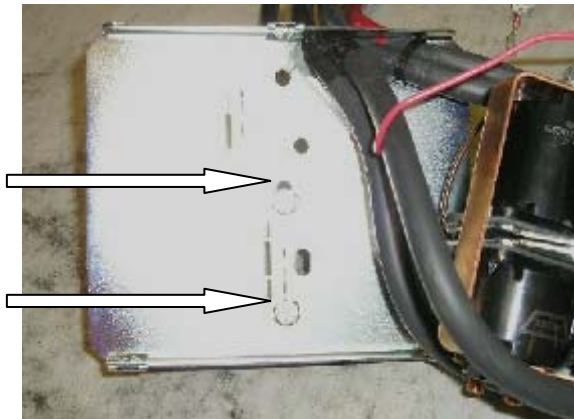

Before

28. Remove the two bolts in the base of the control box and reposition them into the more centralized holes.

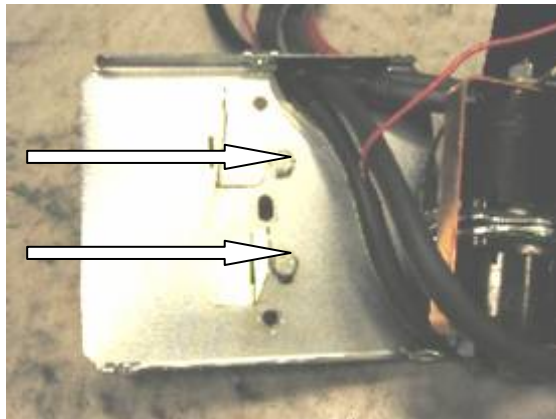

After



29. Place the 4 solenoids over the 2 metal stands that are facing upwards. Make sure they line up with the holes in the base.

30. Replace the 2 cap screws, washers and nuts removed earlier

31. Replace the black cover and refit the three cover screws. (DO NOT OVER TIGHTEN)



32. Bolt the control box bracket to the control box.

33. Fit the two grommets into the round holes in the top of the bull bar then thread the cables through.

34. Mount the control box bracket onto the top pan, using M8 bolts, flat washers and flanged nuts. Use the cable ties to ensure the winch cables are secure, clear of moving parts and sharp edges and tie them together.



35. Place winch on a stand with mounting holes facing upwards and lower bull bar onto winch. Align all four holes, using the original 3/8" bolts that came with the winch in the top two holes and the longer 1 3/4" x 3/8" bolts, supplied in the kit, in the lower two holes plus 3/8" spring and flat washers with each bolt.
36. When all bolts are fitted and finger tight, tighten top holes only, using a stepped ring spanner and remove lower bolts.

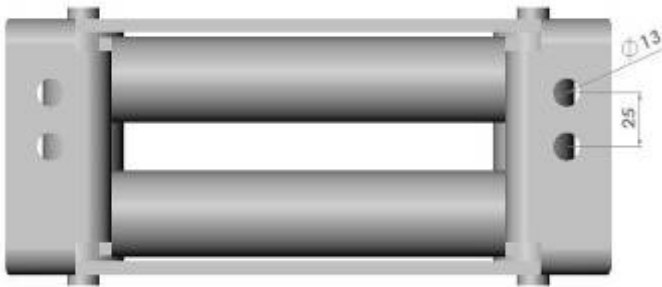

37. Drill two new 13mm holes in the roller fairlead provided in the kit, as shown on the adjacent picture.



38. Fit roller fairlead into cutout and refit bolts and tighten firmly.

NOTE. For ease of tightening lower bolts, use a stepped ring spanner.

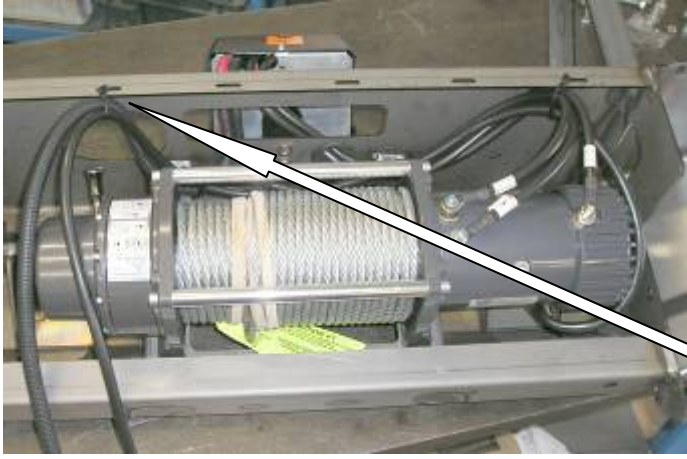

39. Connect the winch control box cables to the winch. Refer to Warn installation instruction manual when wiring up winch.
40. Ensure that all cables are installed well clear of all sharp or moving parts, by using cables ties from bolt kit.
41. Cable tie main cables that go to battery in between underside of bar and brace.

Refer to photo to see where to cable tie to bull bar.

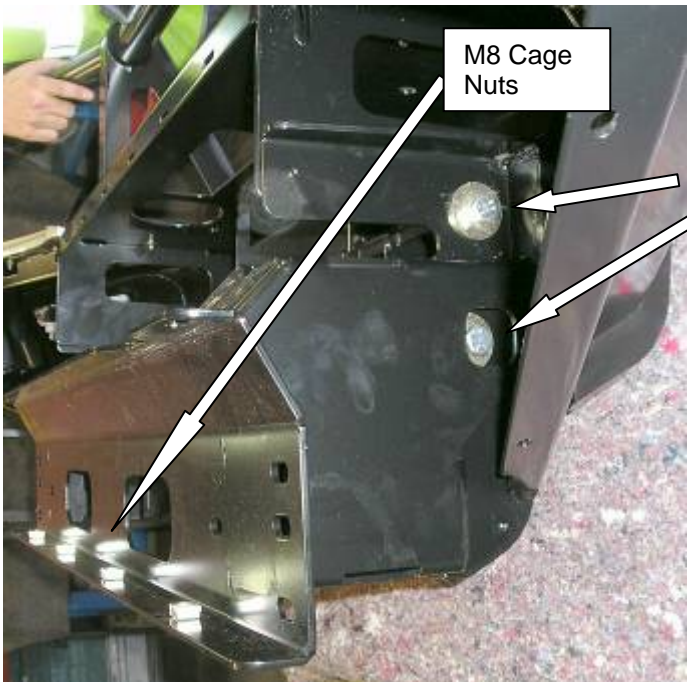

42. Fit four M8 cage nuts to the impact absorber. (Cage nuts to suite 4mm plate) Caged portion to top of bull bar.

43. Fit the impact absorber to the bull-bar using the M10 x 30 bolts, M10 over-sized washers and M10 spring washers. Do not fully tighten these bolts as they will be tightened on the vehicle.



44. Position the bar on the vehicle and fasten it to the chassis studs using the M10 washers, spring washers and nuts provided. Once satisfied that the bar is centrally positioned on the vehicle properly tighten the M10 nuts.



45. Adjust the bull bar position up/down and in/out to achieve uniform gaps between the bar and the fenders on each side of the vehicle. The nominal clearance between the bull-bar and the fenders is 20mm. Firmly tighten the bolts fitted at step 44.

The grill may be loosely positioned, if required, to check fitment of the bull-bar.



46. Once satisfied with the position of the bull-bar, using a 10mm drill, drill through the 10mm holes in the impact absorber, 2 holes per side, and secure using the M10 x 30 bolts, two flat washers per bolt, spring washers and hex nuts.



47. Position the wing trims to fit uniformly around the vehicles headlamps (attached to the bull-bar at step 20) and tighten the M6 nuts.



48. Fasten the lower grill bracket to the vehicle head lights, as shown, using M8 x 25 black bolts, flat washers, spring washers and flange nuts.



49. Reassemble the vehicle's grill removed at step 1; make sure the 2 lower grill tabs are pushed into the clips in the lower grill bracket. Bend lower grill bracket tab upwards slightly.

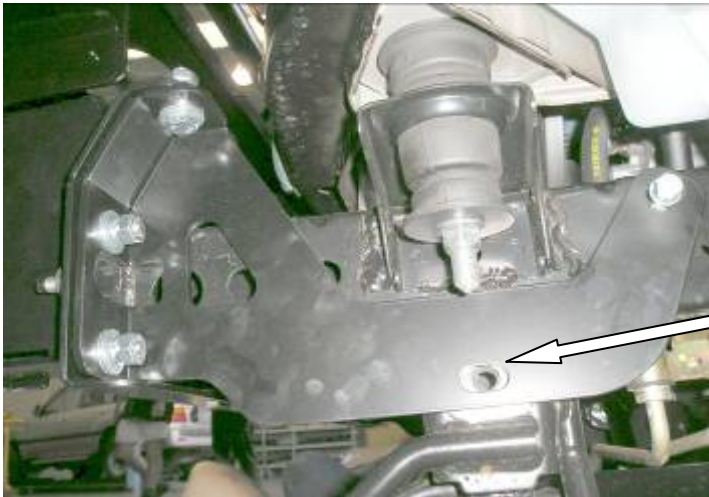

50. Fasten the chassis-stiffening bracket to the chassis and the impact absorber as shown. Fasteners required include: six M10 x 35 bolts, twelve M10 flat washers, six M10 spring washers, six hex nuts, two M8 x 25 bolts, two flat M8 washers and two M8 spring washers.

Leave bolt hole clear for step 57.

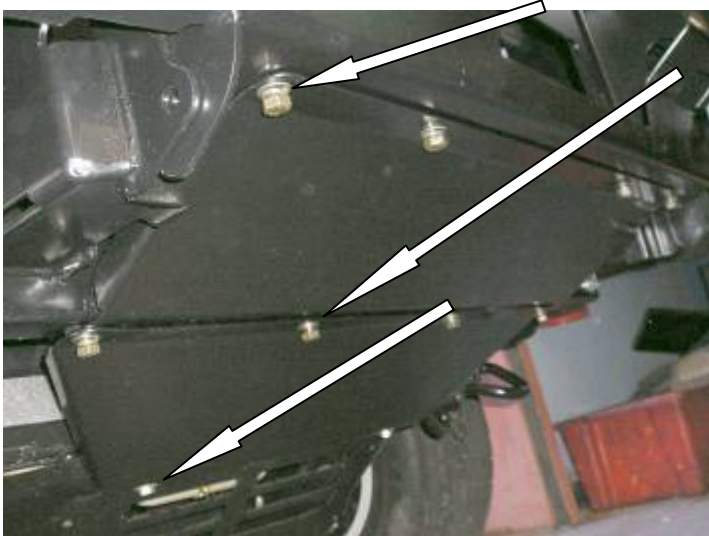

51. Fit the centre stone guards as shown using M8 x 25 black bolts, black M8 flat washers and black M8 spring washers.

Use the original bolts in the lower two holes.



52. Push the tube through the holes in the top of the buffer and fix using the M12 X 40mm bolts washers and spring washers.

FOR WINCH BUMPERS, SKIP THIS STEP.



53. Fit the M6 cage nuts to the wing stone guards – 5 cage nuts to each side (10 off in total).

Make sure the plastic wheel liner on the LH side of the vehicle has been disconnected from the washer bottle before fitting the wing stone guards.



54. Fit the wing stone guards to the bar / vehicle using M6 x 20 black bolts, M6 black washers, M6 black spring washers, M12 x 30 bolts, M12 washers, and M12 spring washers.

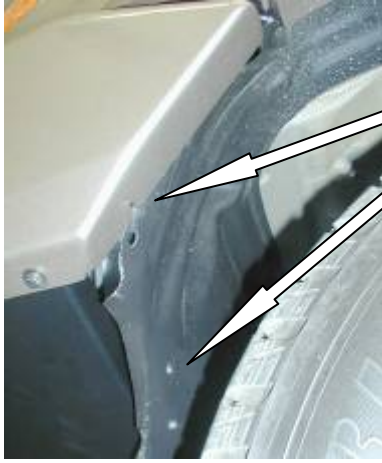

55. Cable tie the plastic wheel liner on the LH side of the vehicle to the two holes provided in the wing and the wing stone guard, as shown in the adjacent photo.



56. Cut the lower part of the plastic wheel liner that hangs below the wing stone guard with a pair of scissors or sharp knife.

For Vehicles Manufactured May 2006 and Onward: - The above two steps will need to be repeated on the Right Hand Side of the Vehicle also.



57. If fitting optional driving lights to vehicle do so at this stage. Guide ratchet spanner between the upper and lower pans, as shown, to tighten the lights to the bar.



58. Fit the plastic plugs into the square holes in the lower pan. Fit the number plate to the bull bar using the black self-tapping screws. The two photos display the number plate positions for both winch and non-winch bars.



Provision for a high-lift jack is provided on both sides of the bar.



59. If no winch is fitted to the bar, wrap the rubber extrusion around winch cover. Place washers over the winch cover fixing holes located on the top middle face of the winch bar. Place the winch cover on top of the bar inline with the mount holes. Bolt together using the M6 button head stainless steel screws and M6 nuts.



60. There are two diameter 16 holes located on the top face of the bar. If no CB aerials are fitted the holes can be covered with the plastic plugs provided in the fitting kit.

61. When finished make sure all bolts are tightened and that all wiring is clear of hot, sharp and moving parts.



