



FITTING INSTRUCTIONS

Part Number: **3934100 ARB BUMPER BAR**

Suited to **MITSUBISHI PAJERO "NS" 4 DOOR FLARED GXL, VRX AND EXCEED**
vehicle/s: **FITTING KIT 6172459**

****** EXCEED HEADLAMP WASHER SYSTEM IS NOT COMPATIBLE WITH THIS PRODUCT**

WARNING

REGARDING VEHICLES EQUIPPED WITH SRS AIRBAG:

When installed in accordance with these instructions, the front protection bar does not affect operation of the SRS airbag.

ALSO, NOTE THE FOLLOWING:

- ◆ This product must be installed exactly as per these instructions using only the hardware supplied.
- ◆ In the event of damage to any bull bar component, contact your nearest authorised ARB stockist. Repairs or modifications to the impact absorption system must not be attempted.
- ◆ Do not use this product for any vehicle make or model, other than those specified by ARB.
- ◆ Do not remove labels from this bull bar.
- ◆ This product or its fixing must not be modified in any way.
- ◆ The installation of this product may require the use of specialized tools and/or techniques
- ◆ It is recommended that this product is only installed by trained personnel
- ◆ These instructions are correct as at the publication date. ARB Corporation Ltd. cannot be held responsible for the impact of any changes subsequently made by the vehicle manufacturer
- ◆ During installation, it is the duty of the installer to check correct operation/clearances of all components
- ◆ Work safely at all times
- ◆ Unless otherwise instructed, tighten fasteners to specified torque

ARB 4x4 ACCESSORIES

Corporate Head Office

42-44 Garden St
Kilsyth, Victoria
AUSTRALIA 3137

Tel: +61 (3) 9761 6622
Fax: +61 (3) 9761 6807

Australian enquiries
North & South American enquiries
Other international enquiries

sales@arb.com.au
sales@arbusa.com
exports@arb.com.au

www.arb.com.au

GENERAL CARE AND MAINTENANCE

By choosing an ARB Bar, you have bought a product that is one of the most sought after 4WD products in the world. Your bar is a properly engineered, reliable, quality accessory that represents excellent value. To keep your bar in original condition it is important to care and maintain it following these recommendations:



- Prior to exposure to the weather your bar should be treated to a Canuba based polish on all exposed surfaces. It is recommended that this is performed on a six monthly basis or following exposure to salt, mud, sand or other contaminants.
- As part of any Pre Trip Preparation, or on an annual basis, it is recommended that a thorough visual inspection of the bar is carried out, making sure that all bolts and other components are torqued to the correct specification. Also check that all wiring sheaths, connectors, and fittings are free of damage. Replace any components as necessary. This service can be performed by your local authorized ARB Stockist.

FITTING REQUIREMENTS

REQUIRED TOOLS FOR FITMENT OF PRODUCT:

METRIC SOCKET AND SPANNER SETS	POWER DRILL DIA 13.0mm(1/2") CAPACITY
POWER HACKSAW OR JIG SAW	DRILL BITS DIA 7.0 & 10.5,
LARGE "G" CLAMP	PHILIPS AND FLAT BLADE SCREWDRIVERS
TAPE MEASURE	MASKING TAPE
STANLEY KNIFE	SMALL ANGLE GRINDER AND CUTTING WHEEL
WHITE AND BLACK MARKER PENS	PIN PUNCH
HAMMER	

HAVE AVAILABLE THESE SAFETY ITEMS WHEN FITTING PRODUCT:

Protective eyewear		Hearing protection	
--------------------	---	--------------------	---

NOTE: 'WARNING' notes in the fitting procedure relate to OHS situations, where to avoid a potentially hazardous situation it is suggested that protective safety gear be worn or a safe work procedure be employed. If these notes and warnings are not heeded, injury may result.

FASTENER TORQUE SETTINGS:

SIZE	Torque Nm	Torque lbft
M6	9Nm	7lbft
M8	22Nm	16lbft
M10	44Nm	32lbft
M12	77Nm	57lbft

PARTS LISTING			
APPLICATION.	PART NO.	QTY	DESCRIPTION
MOUNT BRACKETS TO VEHICLE	3757510R	1	BRACKET IMP ABS ASSY
	3757510L	1	BRACKET IMP ABS ASSY
	3757508R	1	BRACKET CHASSIS INBOARD
	3757508L	1	BRACKET CHASSIS INBOARD
	3757509R	1	BRACKET CHASSIS OUTBOARD
	3757509L	1	BRACKET CHASSIS OUTBOARD
	3199915	6	PLATE CAGE NUT
	6151302	6	CAGE NUT M10
	6151357	16	BOLT SEMS M10 X 30mm
	6151321	10	NUT FLANGED M10
FIT BULL BAR TO MOUNT BRACKETS	6151357	8	BOLT SEMS M10 X 30mm
	6151321	8	NUT FLANGED M10
FIT CONTROL BOX TO BULL BAR	3756209	1	BRACKET CONTROL BOX
	6151021	2	BOLT M8 X 20mm
	4581044	2	WASHER FLAT M8
	6151132	2	NUT FLANGE M8
NUMBER PLATE TO WINCH BAR	3751451	1	BRACKET NUMBER PLATE
	6151017	4	BOLT M6 X 16mm
	6151046	4	WASHER FLAT M6
	6151128	4	NUT FLANGE M6
NUMBER PLATE TO NON-WINCH BAR	6151384	2	SCREW
	6821189	2	GROMMET
FENDER LINER RE-FASTENING	6151213	6	BOLT M6 X 20mm BZ
	4581082	6	WASHER FLAT M6 LG BZ
	6151128	6	NUT FLANGE M6
FIT WINCH COVER TO BULL BAR IN NON-WINCH APPLICATION	6521031	1	COVER WINCH
	6191005	1	EXTRUSION COVER WINCH
	6151256	2	SCREW BUT HD ST STL M6 X 16mm
	4581304	2	WASHER M6 S/S
	6151128	2	NUT FLANGE M6
INDICATORS TO BULL BAR	6821151R	1	INDICATOR ASSEMBLY RH
	6821151L	1	INDICATOR ASSEMBLY LH
	180302	6	CABLE TIES
	6821152	2	LOOM
	180701	6	SCOTCH LOCKS
LIGHT SURROUND ASSEMBLY	3163015	1	LIGHT SURROUND KIT
	180302	2	CABLE TIES
UNDER WING PANS	6522714R	1	UNDER WING PAN RHS
	6522714L	1	UNDER WING PAN LHS
	4581082	10	WASHER M6
	4581287	10	SPRING WASHER M6
	6151213	10	SCREW M6 X 20 BZ
	6151300	10	CAGED NUT M6
CENTER FRAME TO BAR	6151255	2	BOLT M12 X 1.75 40mm
	4581049	2	WASHER FLAT 1/2"
	4581050	2	WASHER SPRING 1/2"

SIREN MOUNT	3758030	1	BRACKET SIREN MOUNT
	6151303	3	NUT CAGED M8
	4581307	3	WASHER FLAT M8 BZ
	4581047	3	WASHER SPRING M8 BZ
	6151262	3	BOLT M8 X 20 BZ
MISCELLANEOUS	6191014	2	PINCH WELD @ 330mm
	3783282	1	CUTTING TEMPLATE BUMPER
	4581040	2	WASHER FLAT 3/8" (RFL)
	6151074	2	BOLT 3/8" X 1 3/4" (RFL)
	180302	6	CABLE TIES
	3162152	2	PLASTIC PLUG Ø16.0MM
	6151128	12	NUT FLANGED M6
BUFFER KIT SAHARA BAR (5100020)	3162469R&L	1	BUFFER 260 X 230 (HOLE)
BUFFER KIT SAHARA BUMPER (5100030)	3162466R&L	1	BUFFER 260 X 230 (NO HOLE)
5134010 CENTER FRAME (SAHARA BAR ONLY)	6131555	1	TOP TUBE ASSEMBLY

SHADED AREAS INDICATE ADDITIONAL KITS REQUIRED, DEPENDENT ON SAHARA BAR/BUMPER SELECTION.

OPTIONAL LIGHT SETS TO SUIT THIS PRODUCT:

- ◆ ARB 6821201 FOG LAMP SET
- ◆ Up to IPF 900 SERIES FOG OR DRIVING LIGHT SETS

OPTIONAL WINCHES WHICH FIT THIS BULL BAR:

- ◆ WARN 8000, 9000 AND 9.5XP

***** NOTE:**

- **WASHER JET FOR HEADLAMPS, AS FITTED TO EXCEED WILL NOT BE ABLE TO OPERATE WITH BAR IN POSITION.**

BUMPER REMOVAL



1. Remove stone tray



2. Remove plastic scrivenets and bolts securing lower bumper tabs.



3. Remove screws securing fender liner to bumper and bumper bracket in wheel arch area.
4. Remove liner and bumper retaining brackets.

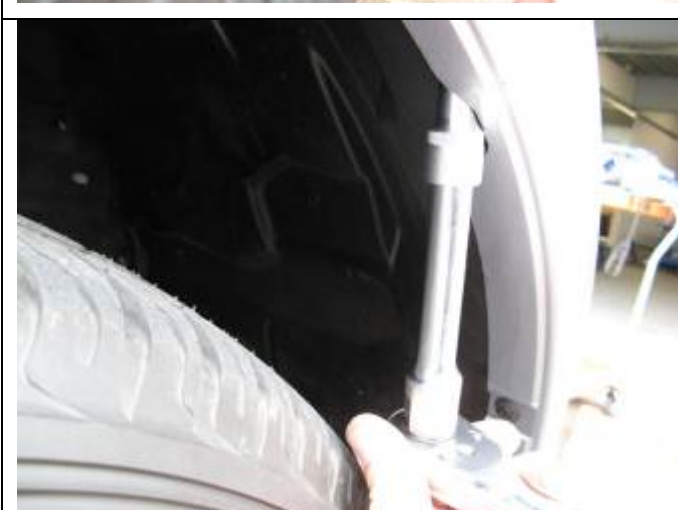

5. Undo vertical screws securing bumper to fender

BUMPER REMOVAL



6. Remove scrivets securing grille across the top and pull grille upward to release lower clips.



7. Remove upper bumper retaining scrivets.



8. Remove number plate.
9. Remove scrivets behind number plate position



10. Free the end of the flare from the bumper by pulling outward in the lower region as shown.

BUMPER REMOVAL



11. With flare loose to bumper, pull the bumper end outward and forward to release it from the holding bracket on both sides then remove bumper entirely.
12. Place bumper on soft non abrasive surface as the upper part will be reused and should not be damaged.



13. Undo upper cross member fasteners as shown on both ends as shown.



14. Remove cross member central fasteners then set aside.



15. If fitted, remove fog lamps including trim rings and set aside.

BUMPER REMOVAL



16. Remove the two buffer blocks from the bumper. Fixing screws are accessed from rear of bumper as shown.



17. If washer assemblies fitted (circled for reference in picture), remove and set aside.



18. Place bumper back on vehicle including securing wing area of bumper into retaining clips.

TRIMMING OF BUMPER



19. To familiarise yourself with the cut line location, do a dry run placing template in position on RHS of vehicle. Note key alignment points to headlamp lower corner, distance to horizontal cut line from lower bumper edge and fender rubber trim edge. Spot mark ends of cut lines to flare and inboard end of cut line to bumper face.



20. Remove template from vehicle and cut along designated cut line, also if required in various other areas to assist aligning to vehicle, as shown.



21. Refit template to vehicle and mark cut line (LHS shown).



22. Using a spirit level continue marked cut line onto flare.
23. Follow steps 21 and 22 on other side of vehicle.

TRIMMING OF BUMPER



24. Remove bumper and apply masking tape to either side of cut line to prevent damage to bumper when cutting.



25. Using a jig saw or similar suitable cutting device, cut along the line. The cut through the top of the bumper is aligned with the edge of the bumper recess as shown.

NOTE: In the outboard section of the bumper, a metal bracket will need to be cut through as well as the plastic.



Warning: Cutting operations can result in flying debris, safety glasses should be worn.



26. Mask around the marked cut lines on the flares then using cutting tool cut off end of flares
27. Using a file remove all sharp edges and burrs from the cut area.



Warning: Cutting operations can result in flying debris, safety glasses should be worn.



28. Mark cut lines on each end of the cross member. The edge of the cut is 25mm inboard of the M6 hole as shown.

TRIMMING OF BUMPER



29. Using a jig saw or angle grinder with cutting wheel, cut along the line.



Warning: Grinding operations can result in flying metal sparks and debris, safety glasses should be worn.



30. Mark and drill a 7mm hole on the LHS of the cross member, in the same position as the existing hole on the RHS.
31. Deburr cut edges and spray paint them to prevent corrosion.



Warning: Drilling operations can result in flying metal debris, safety glasses should be



32. Refit ends of cross member in original positions.



33. Refit bumper ends
34. Mark a line on the bumper hard up against the lip of the rubber trim on the flare.

NOTE: This is in preparation for a slot which allows the pinch weld, fitted later in the process, to seamlessly fit across the end of the flare onto the bumper.

TRIMMING OF BUMPER

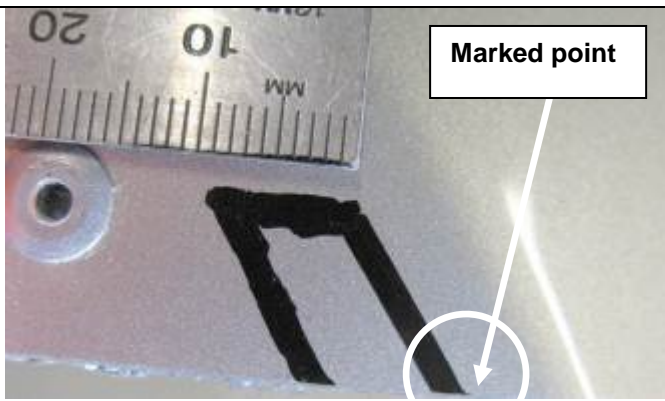

35. Remove the bumper ends.
36. Mark out slot as shown 20mm high x 10 mm wide, starting **next** to the marked point from step 34 (circled).

CRITICAL: Slot should not be seen once flare is refitted with pinch weld in place.

37. Notch out the marked area with a grinder and cutting wheel. Note that there is a metal bracket behind the plastic.
38. Refit the bumper sections, clipping the outboard area into the fender clips and the inboard area into the clips on the cross member ends.
39. Fit the existing screw to vertically secure the bumper end to the fender.

Warning: Grinding operations can result in flying metal debris, safety glasses should be worn.

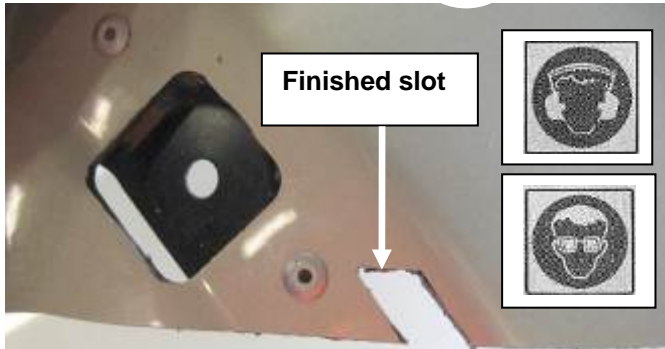

40. To secure inboard end of bumper section, fit a cable tie to the remaining lug on the bumper and through the newly drilled hole in the cross member ends. This cable tie when pulled tighter can adjust the position of the bumper to the bull bar, so wait until after the bar is fitted before trimming the cable tie off.

NOTE: Viewed from underneath



41. Mark and then trim one end of each of the pinch welds to suit the angle of the wheel arch area of the flare. Use a cutting wheel in a grinder as there is a metal spring channel frame inside the pinch weld.



Warning: Cutting operations can result in flying debris, safety glasses should be worn.



42. Fit the pinch weld to cut edge both sides.

FIT MOUNT BRACKETS



43. ***If siren fitted*** to front outboard side of RHS chassis, it will need to be removed to be refitted later.
44. Use a pin punch to punch through the steel pins then drill out the rivets and remove siren



Warning: Drilling operations can result in flying debris, safety glasses should be worn.



45. Fit mount bracket sets with reinforcing plates to front of vehicle as shown. Use M10 fasteners sets to hold in position.

NOTE: Return flanges on brackets face inboard as shown.



46. Use a large 'G' clamp to hold reinforcing brackets hard up against the chassis sides. (LHS shown)
47. When in place tighten bolts.



48. Outboard reinforcing bracket shown on RHS.

FIT MOUNT BRACKETS



49. **If refitting siren** fit cage nuts as shown top view
50. Fit bracket to side of brace shown step 48 on outer RHS of vehicle using M10 SEMS bolts and cage nuts supplied. **NOTE: You may have to loosen bolts in front flange of reinforcing bracket**
51. Fix siren to bracket with M8 bolt and washer sets, reconnect electrical and tighten all bolts to specified torque.

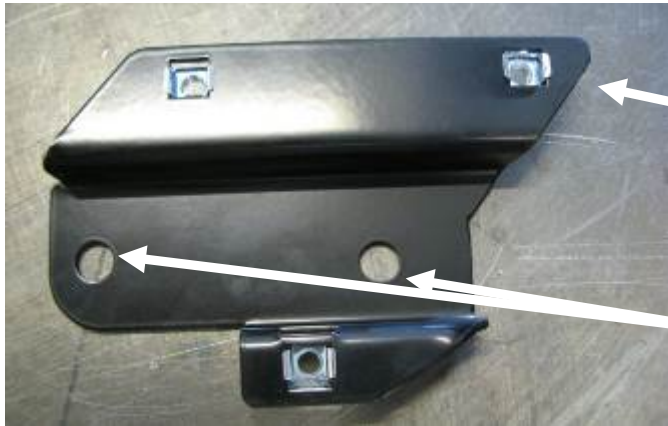

This end to front of vehicle

Use these holes to bolt to vehicle with reinforcing bracket in between



52. Inboard bracket shown on RHS
53. Drill 1 x Dia 10.5 hole on the inboard side and 2 x holes on the outboard side using existing holes in reinforcing brackets to guide drill.



Warning: Drilling operations can result in flying metal debris, safety glasses should be



54. Fit 6 x cage nuts to access arms as shown.

FIT MOUNT BRACKETS



55. Estimate the bend profile and then bend each of the access arms so that the cage nuts will align with the 3 x drilled holes in each chassis.
56. Feed the arms through the lower holes in chassis one at a time and secure with M10 SEMS fasteners through holes in brackets.
57. Once all are through and started do up tight.



58. Bend the arms back and hard against the chassis.
59. At front lower flange on mount bracket, drill Dia 10.5 through chassis using the lowest hole in the mount bracket as a guide.
60. Insert an M10 SEMS and using an M10 flange nut inserted into the chassis end secure and do up tight.



Warning: Drilling operations can result in flying metal debris, safety glasses should be



61. Drill Dia 10.0 pinning hole in lower flange of mount bracket into the vehicle crossmember



Warning: Drilling operations can result in flying metal debris, safety glasses should be

FIT MOUNT BRACKETS



62. Fit M10 SEMS bolt and load flange nut from inside cross member then do up tight.



63. Reclip electrical loom connector into new bracket flange both sides of vehicle.

PREPARATION OF BAR

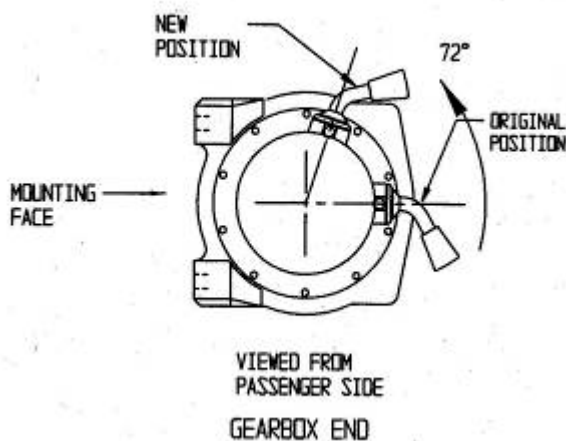

IF FITTING WINCH STEPS FOLLOW STEPS 59-70, IF NOT FITTING WINCH SKIP TO STEP 71.

64. To place the winch clutch handle in a convenient location the winch gearbox must be rotated 2 hole spaces, (72 degrees), in an anti-clockwise direction when viewed from the gearbox end . Place the winch on its end and remove all gearbox bolts.

Gently raise the gearbox just enough to rotate it as shown. Do not completely remove the gearbox as this will damage the gasket. **Refit all of the bolts and tighten.**

NOTE :- Take care not to lift the assembly more than a couple of millimetres while rotating to the desired position to avoid unmeshing the gears.

PREPARATION OF BAR

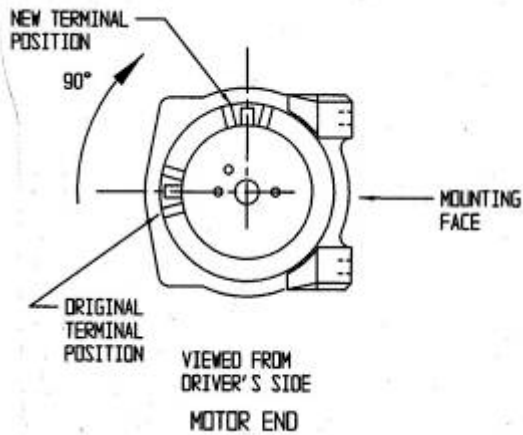

65. To place the **winch motor** in the correct location the **winch motor** must be rotated 90 degrees, in a clockwise direction when viewed from the motor end.

Gently raise the motor just enough to rotate it. Do not completely remove the motor as this **MAY** damage the gasket. **Refit all of the bolts and tighten.**

NOTE :- Take care not to lift the assembly more than a couple of millimetres while rotating to the desired position to avoid unmeshing the gears.



66. Insert winch into position as shown

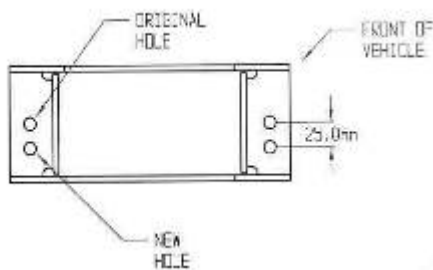

67. If the RFL does not have the second set of holes 25mm lower than the ones marked original in this sketch, mark out and drill a new hole set of the same diameter as original.



Warning: Drilling operations can result in flying metal debris, safety glasses should be



68. Insert RFL to front of bull bar and pull through cable eye.
69. Do bolts up tight
70. Fit hook to cable end

PREPARATION OF BAR

71.



72. Fit control box bracket



73. Fit control box

74. Connect the winch control box cables to the winch motor. Refer to the Warn handbook for additional information. Connect the long winch + & - cables to the vehicle after the bar is installed. **Refer to the Warn winch manual for vehicle wiring instructions.**

CAUTION: All wiring must be securely cable tied clear of any hazardous or potentially hazardous working areas of the winch and must not be exposed to sharp edges or susceptible to fretting.



75. Fit number plate bracket as shown using M6 hardware.



76. Fit number plate located as shown using M6 hardware.

Note: ARB combination bull bar shown

PREPARATION OF BAR



77. Insert the side buffers through the holes and fix using the M6 flange nuts.

NOTE: If fitting top tube use buffers that have a hole in the top.



IF NOT FITTING WINCH

78. Fit 2 x large round head grommets to front face of bull bar in square holes.



79. Fit number plate using black dome head screws inserted into grommets.



80. Apply rubber mold to edge of winch hole cover panel and trim off excess.

PREPARATION OF BAR



81. Fit panel to top face on bull bar using 2 x M6 dome head stainless steel screws, flange nuts and stainless steel flat washers.

NOTE : The stainless steel flat washers are to be sandwiched between panel and top face of bull bar to stop the panel pulling down to form depression around screw heads.



82. Support bull bar on lift device if available or with the help of one or more assistants lift the bull bar into position on the mount brackets.

Note: ARB combination bull bar shown

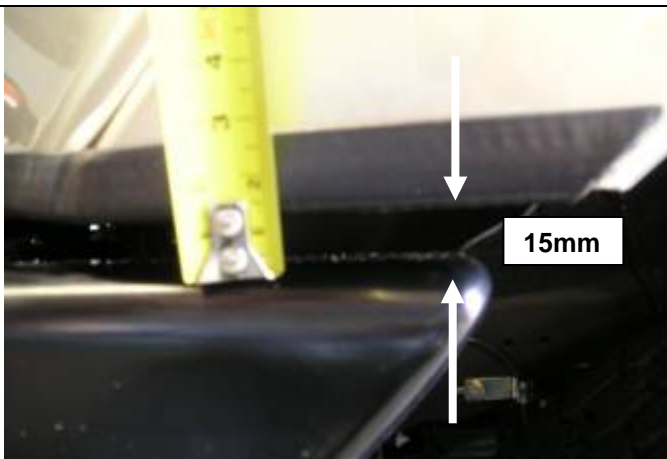

83. Bolt up bull bar to mount brackets using M10 SEMS and flange nuts but do not tighten.

84. Adjust position of bull bar so that there is an even 15mm clearance to the underside of the fender.

85. Tighten up M10 SEMS and flange nuts



86. Drill pinning holes using Dia 10.5 drill through existing holes in mount bracket lower flange area.

87. Insert M10 SEMS and flange nuts and do up tight.



Warning: Drilling operations can result in flying metal debris, safety glasses should be worn.

FIT BAR TO VEHICLE



88. Tuck fender liner into inside rear of wing flange.



89. Drill holes in fender liner using Dia 7.0 holes in wing return flanges as a guide and fasten fender line with 4 x M6 black bolts, washers and flange nuts.



Warning: Drilling operations can result in flying debris, safety glasses should be worn.



90. Drill hole in fender liner and cross beam as shown and secure liner with M6 black bolts, washers and flange nuts.



Warning: Drilling operations can result in flying metal debris, safety glasses should be



91. Carefully, using a sharp knife or hacksaw trim off the fender liner co-incident with the lower edge of the cross beam.

FIT BAR TO VEHICLE



92. Using a black spray pack, paint the exposed color coded area of the cross beam so it does not show.



93. Refit grille, loading vertically, noting that there are pins on the lower section, which align with holes in the top face of the bull bar.
94. Refit stone tray removed at step 1
95. Check that the indicators are not rubbing on the cut edge of the bumper, if so, locally trim the bumper edge.

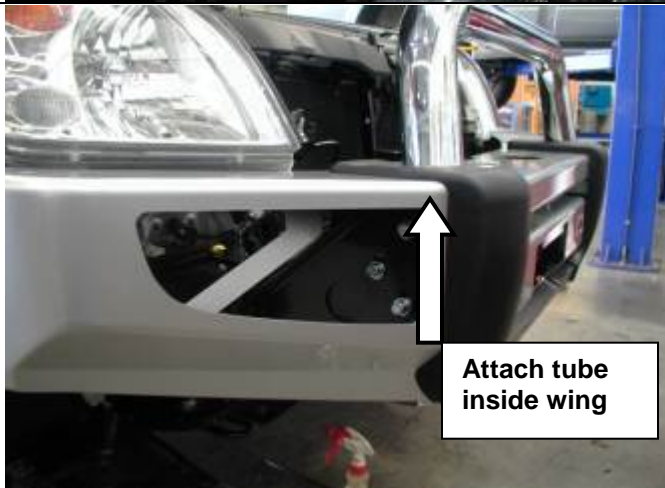

If fitting Top Tube

96. Attach the tube to the bar by pushing through the holes in the buffers, fix using two M12 x 1.75 x 40mm bolts, 1/2" flat and spring washers.



97. Remove indicators from cartons and then remove screws and speed nuts from each light. These fasteners are not to be reused – new screws are supplied in the fitting kit

FIT BAR TO VEHICLE

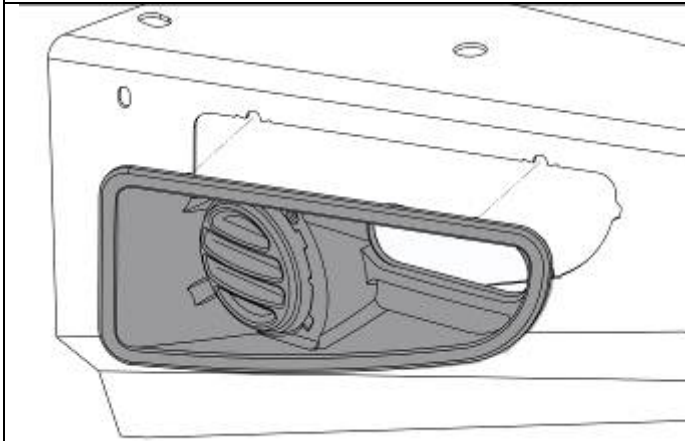

98. Assemble and install combination light surrounds (p/n 3163015) as per instructions no. 3786421 supplied with surround kit. Note: Optional fog lamps can be installed at this point as per fitting instruction no. 3783315 supplied with fog lamp kit no. 6821201.

99. Wire the combination lamp to the vehicles indicator and clearance lamps.

CAUTION: Cable-tie all cables together and keep all cables clear of sharp edges and all moving parts.



100. Fit the M6 cage nuts to the under wing pans and fit to the underneath of each wing using M6 x 16 Hex bolts, M6 Washers and M6 Spring Washers.

NOTE:

- ◆ **Connect wiring to lights and winch. Refer to winch manufacturers installation instructions**
- ◆ **Check operation of all lights.**
- ◆ **Check winch operation**



Note: Vehicle shown without top tube