



RHINO-RACK

Aerodynamic & Heavy Duty Roof Rack Systems

RLT500 - Rhino Track Leg Kit



Important: Please read these instructions carefully prior to installation. Please refer to your fitting instruction to ensure that the roof racks are installed in the correct locations. Check the contents of kit before commencing fitment and report any discrepancies. Place these instructions in the vehicle's glove box after installation is complete.

Care Instruction: Clean vehicle roof prior to fitting Rhino roof racks.

Important Information

Maximum carrying capacity: 100kg/220lbs evenly distributed over the crossbars. Please refer to your vehicle manufacturers handbook for maximum roof loading. Always use lower of these two figures.

Recommendations:

It is essential that all bolt connections be checked after driving a short distance when you first install your crossbars. Bolt connections should be checked again at regular intervals (probably once a week is enough, depending on road conditions, usage, loads and distances travelled). You should also check the crossbars each time they are refitted. Make sure to fasten your load securely. Please ensure that all loads are evenly distributed and that the centre of gravity is kept as low as possible.

Use only non-stretch fastening ropes or straps:

Caution: The handling characteristics of the vehicle changes when you transport a load on the roof. For safety reasons we recommend you exercise extreme care when transporting wind-resistant loads. Special consideration must be taken into account when cornering and braking.

Please remove crossbars when putting vehicle through an automatic car wash.

Load Ratings:

Maximum permissible load is 100kg/220lbs per pair of cross bars (include the weight of the cross bars, 5kg/11lbs). When crossbars are to be used in off-road conditions, please build a safety factor of 1.5 into this load limit, 66kg/145lbs for off-road use. Although the roof racks are tested and approved to AS1235-2000, off-road road conditions can be much more rigorous. However, increasing the number of crossbars does not increase the vehicles maximum permissible roof loading.

Note for Dealers and Fitters:

It is your responsibility to ensure instructions are given to the end user or client.

Rhino-Rack
3 Pike Street, Rydalmere,
NSW 2116, Australia.
(Ph) (02) 9638 4744
(Fax) (02) 9638 4822

Document No: R038
Prepared By: Craig Jones
Authorised By: Gary England

Issue No: 01
Issue Date: 15/09/2010

These instructions remain the property of Rhino-Rack Pty Ltd and may not be used or changed for any other purpose than intended.



RLT500 - RLCP Track Leg Kit

Parts List

Item	Component Name	Qty	Part No.
1	End cap	2	M002
2	M6 x 40mm security screw	2	B085
3	Aero bar adaptor	2	M155
4	M6 spring washer	2	W004
5	M6 x 12.5mm flat washer	2	W003
6	RLCP leg	2	M123
7	M10 channel nut	2	N024
8	Top pad	2	M173
9	M10 x 38mm flat washer	2	W022
10	Base pad	2	M172
11	M10 shake-proof washer	2	W021
12	M10 x 20mm hex bolt	2	B003
13	Dowel nut housing	2	A341
14	M6 x 16 dowel nut	2	N027
15	Pad cover plate	2	M126
16	5mm security allen key	1	H021
17	Fitting instruction	1	R038

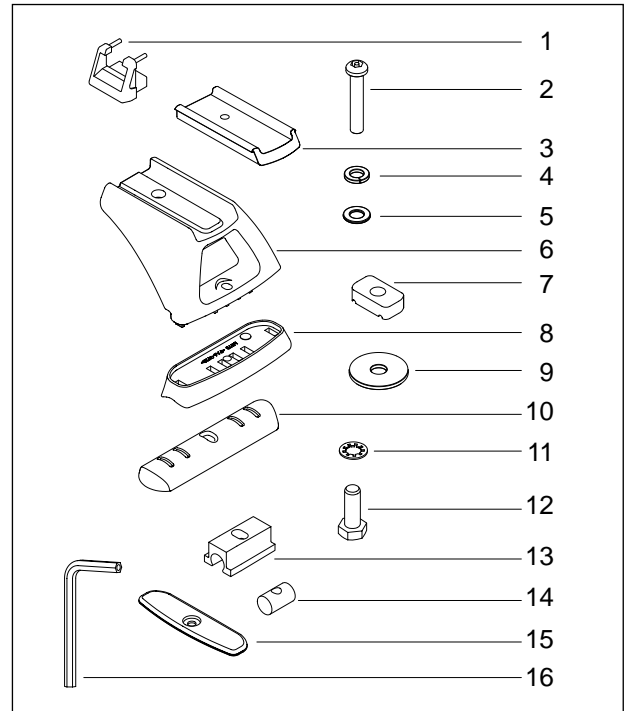

Tools Required:

5mm Security allen key, provided in kit.
5/8 or 16mm spanner.

Measuring tape.

Refer page 4 for vehicle supplement fitting instruction.

1

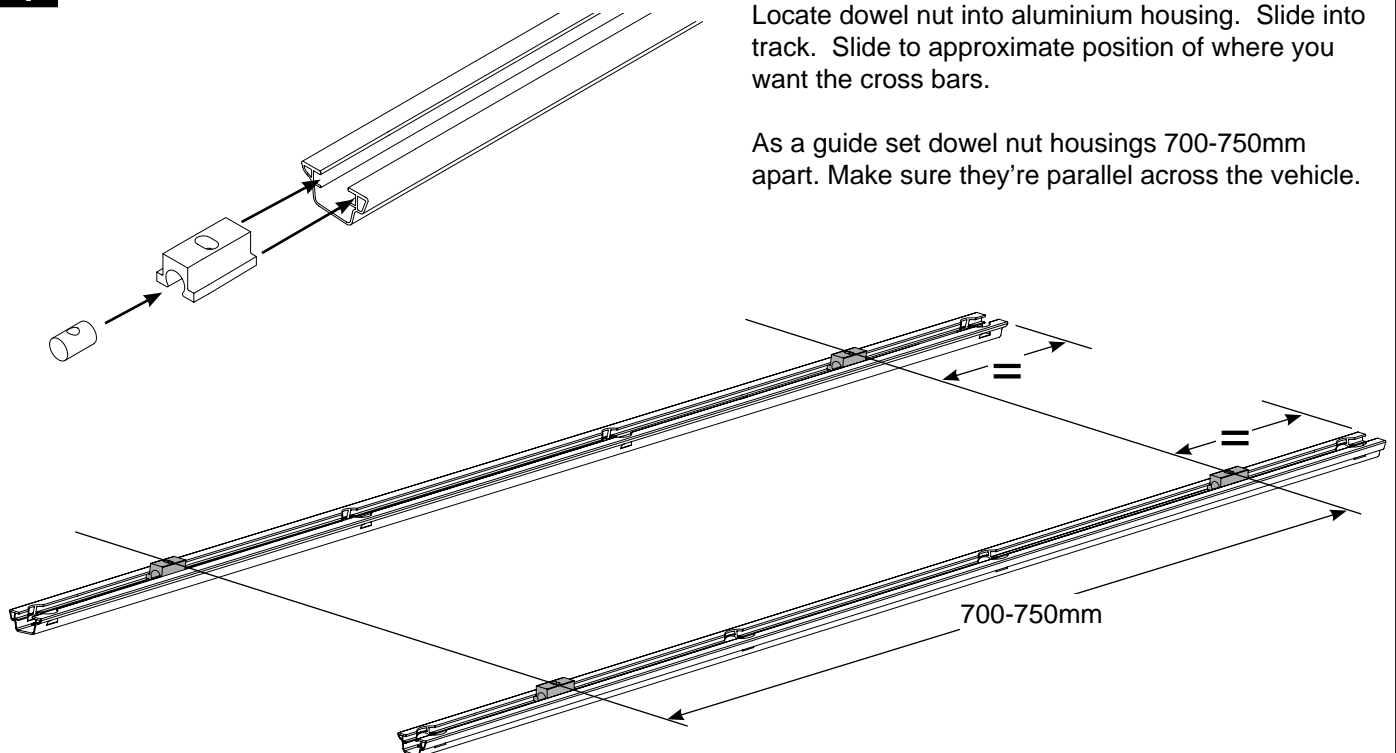



RLT500 - RLCP Track Leg Kit

2

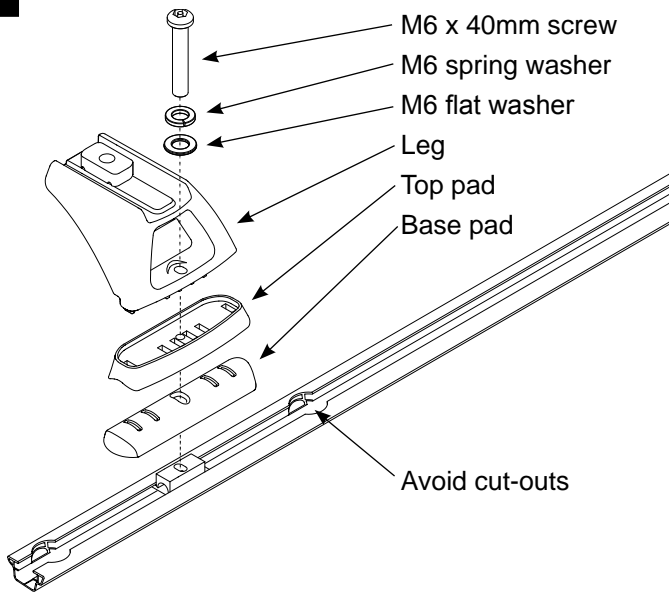

Attach the legs to track using supplied screws and washers. Finger tighten only.

Make sure to that aluminium dowel nut housing is not placed under cut-out holes in the track.

3

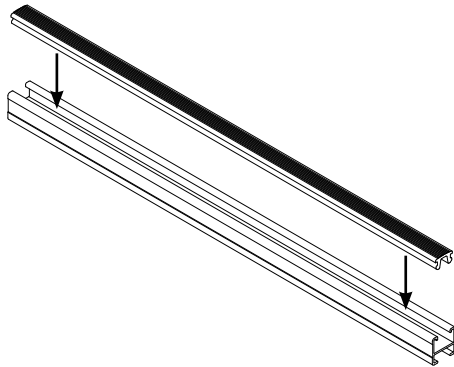

Insert crossbar rubber.

4

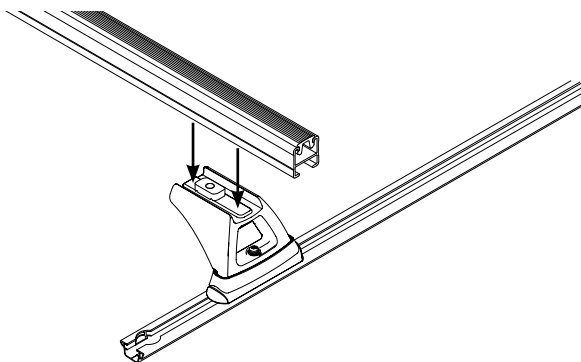

Attach crossbar.

Channel nut must fully locate across the bar.

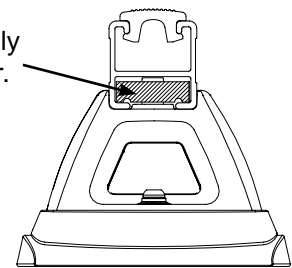

5

Adjust cross bar overhang to be equal both sides. Once adjusted tighten M10 crossbar bolts to **15-16 Nm (132-141 lbf.in)**. Then fasten M6 security screws to **3-4 Nm (26-35 lbf.in)**

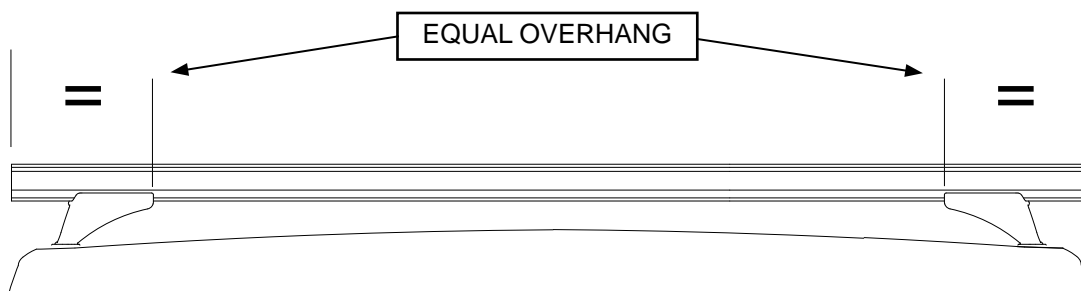



RLT500 - RLCP Track Leg Kit

6

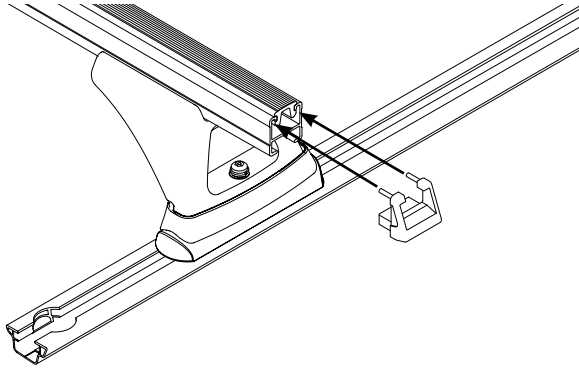

Fit end caps. A rubber mallet may be used to knock them in.

7

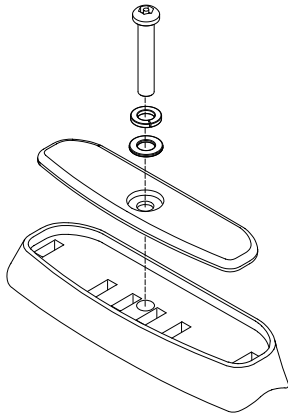

Pad cover plates are provided for when crossbars are removed.

Supplement fitting instruction information

TOYOTA Hilux: For specific fitting, please refer to instruction RR131 included in RTS track kit.

CHEVROLET Trailblazer LS Sport Utility & LS Extended Sport Utility, see diagram below. Remove plastic end covers to gain access to the mounting groove of the roof rail track.

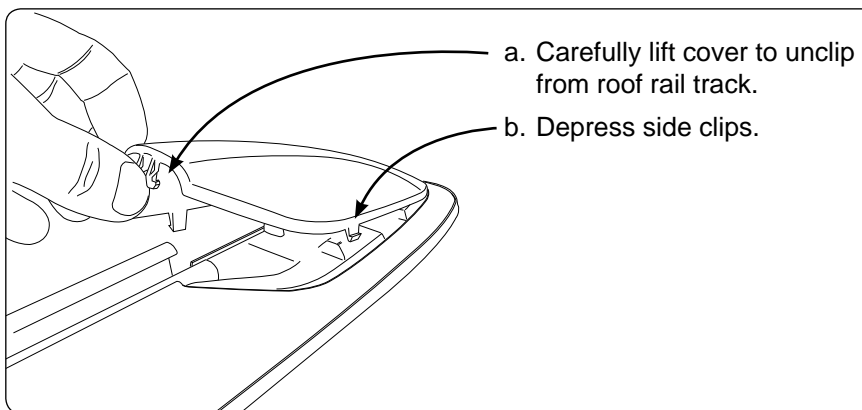

Slide dowel nut housing into track. Clip plastic cover back in place

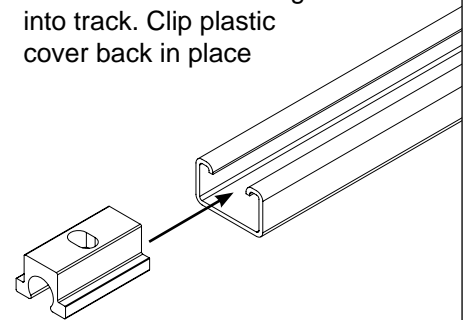



RHINO-RACK

Aerodynamic & Heavy Duty Roof Rack Systems

Warning!

Please follow these steps when drilling the roof (step 6) to avoid damaging the side curtain airbag mechanism. Failure to follow these steps will result in vehicle damage.

1

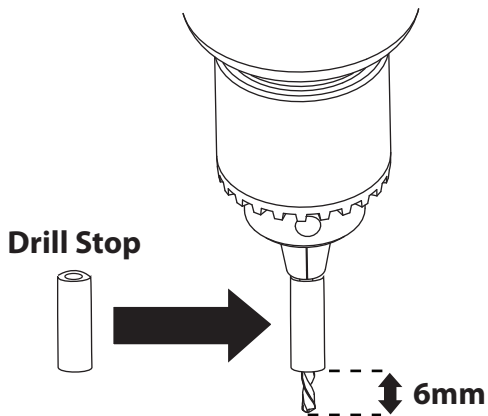

Warning!
MAXIMUM Drill Depth is 6mm.

2

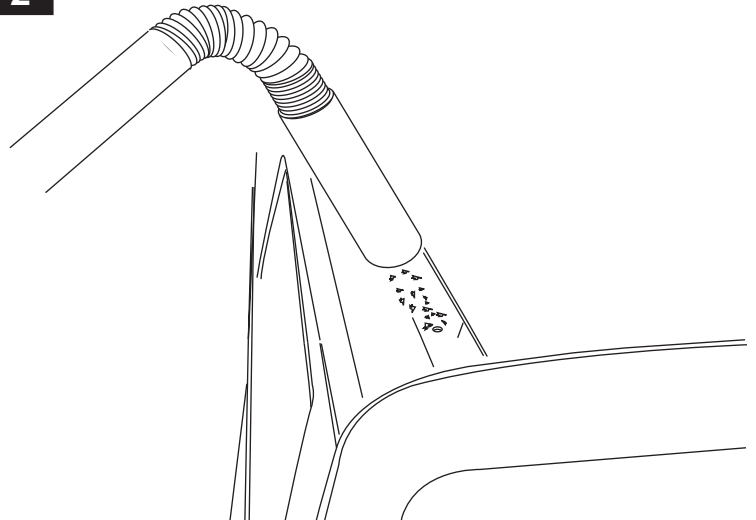

Drill approximately halfway and then use a vacuum to remove swarf from roof channel. Continue drilling the hole, repeat operation for remaining holes.

3

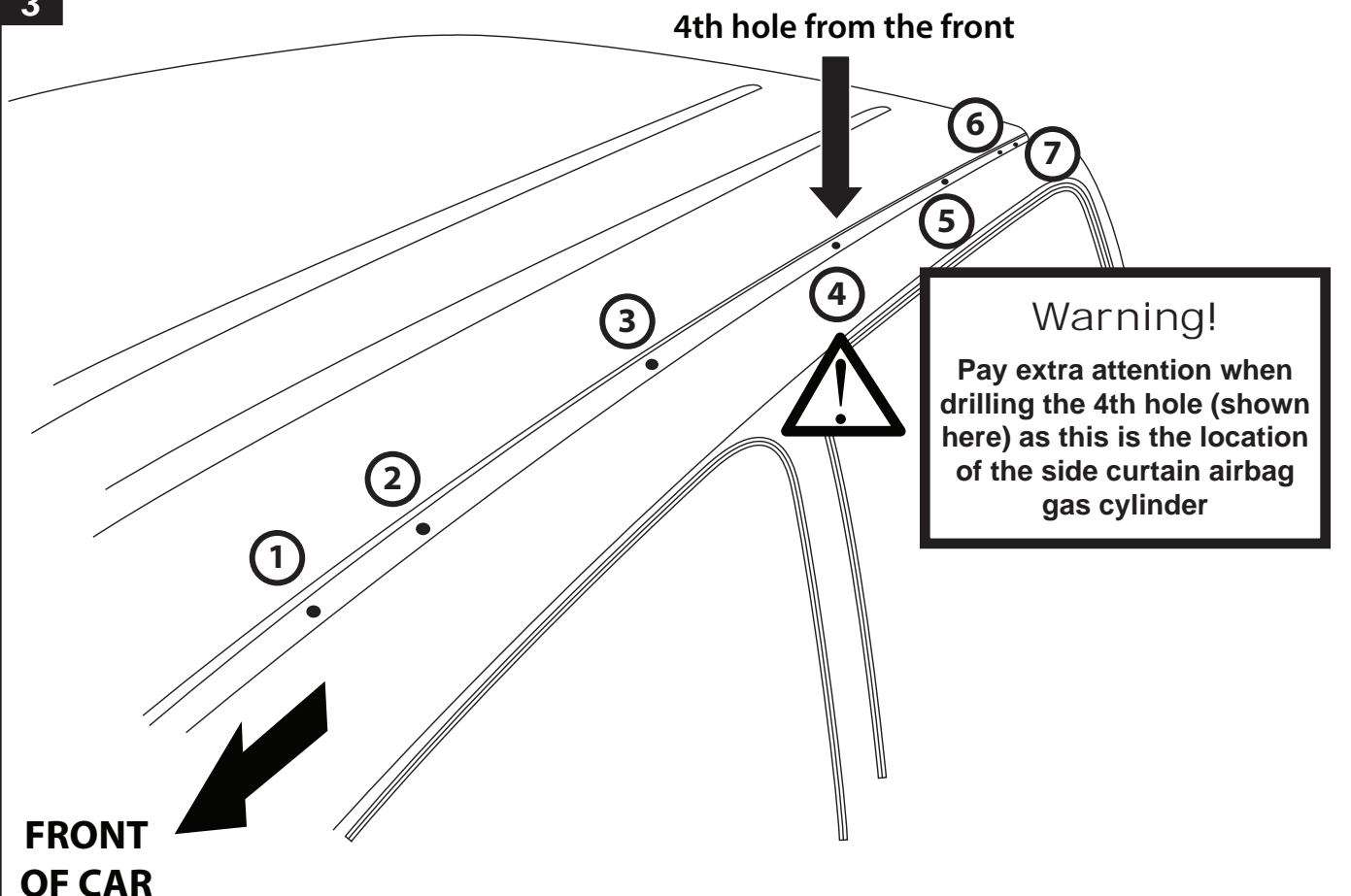



RHINO-RACK

Aerodynamic & Heavy Duty Roof Rack Systems

Toyota Hilux Rhino Heavy Duty - Two Bar Trackmount System

Important: Please read these instructions carefully prior to installation.
Please refer to your fitting instruction to ensure that the roof racks are installed in the correct locations.
Check the contents of kit before commencing fitment and report any discrepancies
Place these instructions in the vehicle's glove box after installation is complete.

Note - Refer Step 15 for crossbar positioning

Parts List

Maximum carrying capacity: 100kg

Item	Component Name	Single Cab	Extra Cab	Dual Cab	Part No.
1	Track Mount End Cap FL & RR	2	2	2	M215
2	Track Mount End Cap FR & RL	2	2	2	M214
3	Hilux Track	1 Pair	1 Pair	1 Pair	
4	Heavy Duty Rubber Buffer 1375mm	1	2	2	R004
5	Heavy Duty Crossbar End Cap	2	4	4	M002
6	Heavy Duty Crossbar 1375mm	1	2	2	A020
7	M6 x 35mm Button Security Screw	2	4	4	B092
8	M6 Spring Washer	2	4	4	W004
9	M6 x 12.5mm Flat Washer	2	4	4	W003
10	RCP Leg	2	4	4	M123
11	RCP Top Pad	2	4	4	M173
12	RCP Bottom Pad	2	4	4	M172
13	M6 x 16 Dowel Nut	2	4	4	N027
14	M6 Dowel Nut Housing	2	4	4	A341
15	M10 x 20mm Hex Bolt	2	4	4	B003
16	M10 Internal Shakeproof Washer	2	4	4	W021
17	M10 x 38mm Flat Washer	2	4	4	W022
18	M10 Channel Nut	2	4	4	N024
19	Mounting Pad Cover Plate	2	4	4	M126
20	Rivet	7	9	11	H008
21	5mm Security Allen Key	1	1	1	H021
22	Fitting Instruction	1	1	1	RR 131

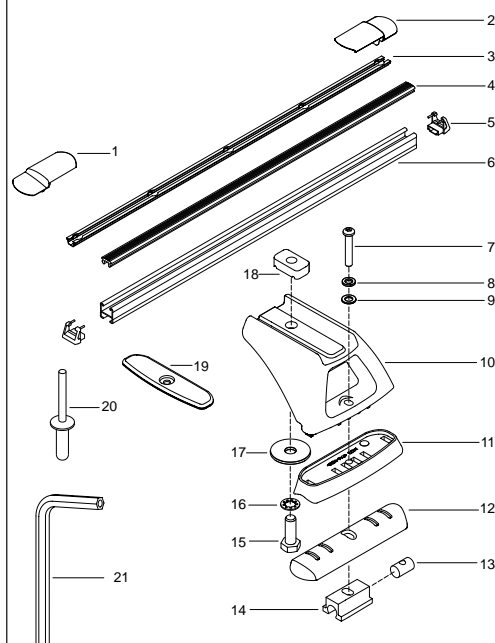

Tools Required

Pneumatic or concertina type rivet gun
Marking pen
Power or Cordless drill
5mm drill bit with depth stop
Vacuum cleaner
Cold galvanizing solution & brush
Selleys Butyl Mastic, Caulking Gun
5mm Security Allen key, provided in kit
5/8 or 16mm spanner or socket wrench
Measuring tape
Hacksaw
Flat Head screwdriver

Care Instruction:

Clean vehicle roof prior to fitting Rhino Heavy Duty Racks.

Layout

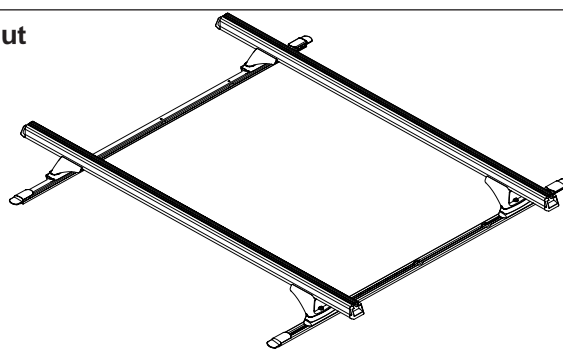

Gently lever the rubber roof trim starting with a screwdriver (wrap tape around end of screwdriver to prevent paint scratching) then using fingertips pull carefully upwards. Small plastic clips are attached to the roof underneath each end of the strip.

1

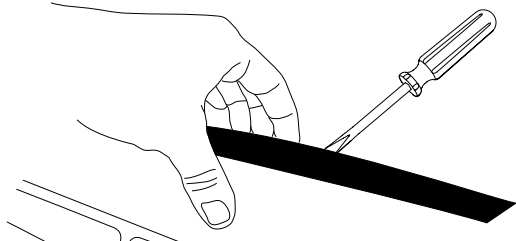

Take note of track orientation when placing in the roof channel. Both tracks are the same.

2

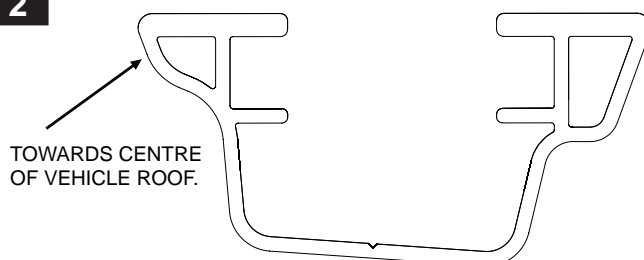

Place the track in the channel and measure from the edge of the windscreen rubber to the front of the track. The use of masking tape will help maintain this measurement while marking out holes for drilling.

3

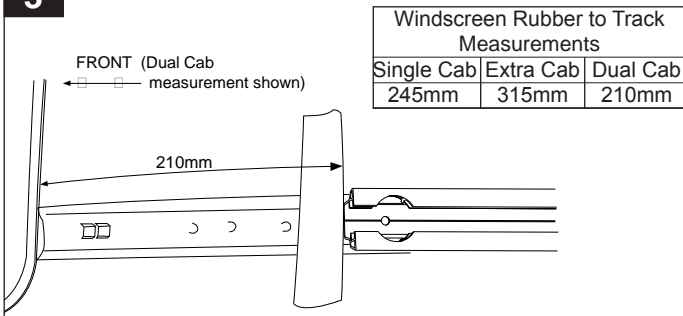

Hold track down tight in roof channel. Mark all holes using a marking pen. Remove the track.

4

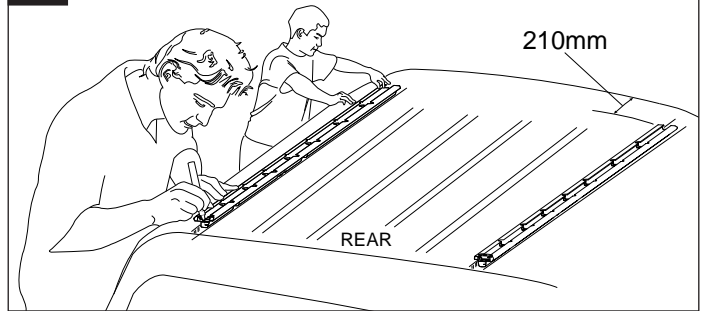

Accurately centre punch all holes before drilling.

5



Marked out holes can now be drilled through using a 5mm drill bit and drill stop. Set the drill stop to ensure you don't drill through the roof lining. Use of a drill stop will alleviate the need to remove the hood lining.

6

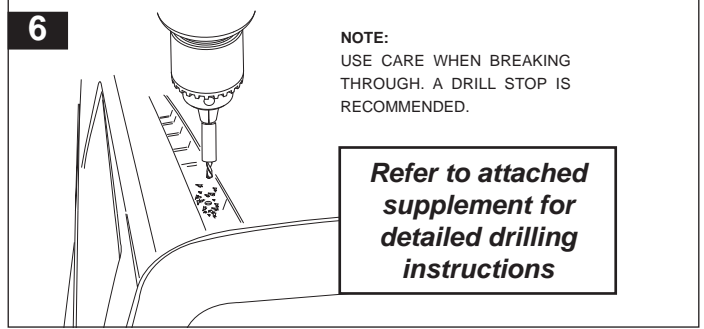

Use a vacuum to remove swarf from the roof channel.

7

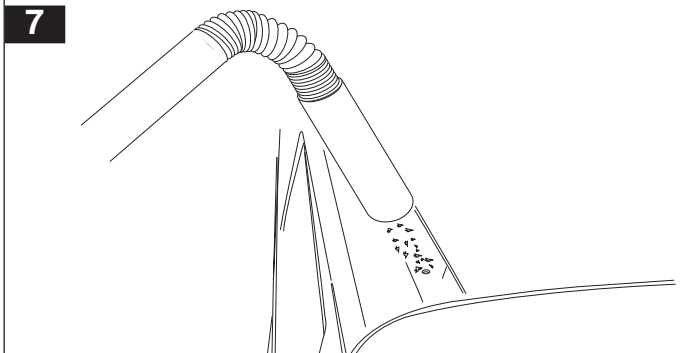

Apply a liberal amount of cold galvanizing solution to the inside and surrounds of all holes. Allow cold galvanizing solution to dry, three to four minutes, then apply a liberal amount of Selleys Butyl Mastic in and around each hole.

8

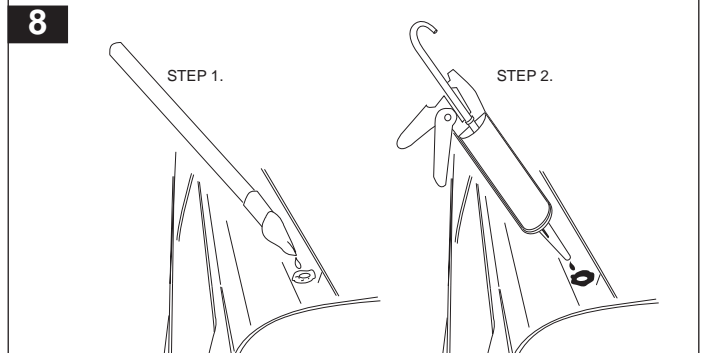

Peel the backing tape off the track. Accurately place the track over the drilled holes in the roof channel using the rivets to position. Make sure track orientation is correct.

9

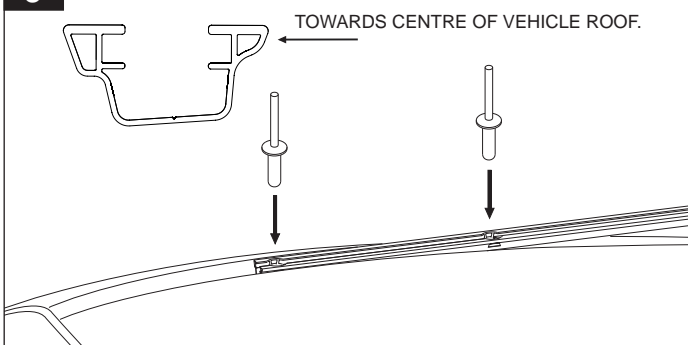

Using either a pneumatic or concertina type rivet gun, rivet the track into place. Make sure all rivets are seated firmly onto the base of the track.

10

NOTE:
Start at the FRONT and work back so the track can be pulled down to follow the roof curve.

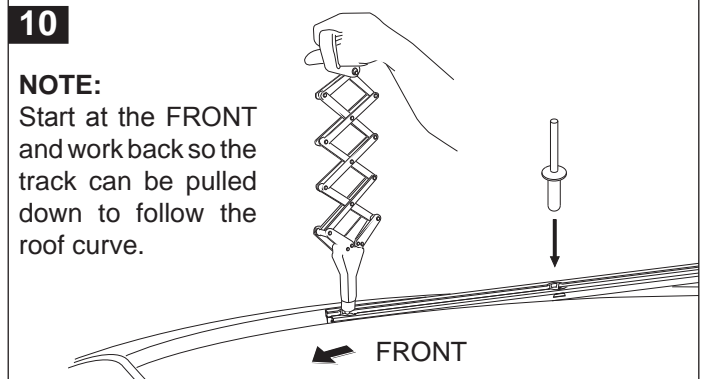

Push the Dowel Nut into the Dowel Nut Housing with the thread facing up through the hole. Slide the unit into the top 'U' section of the track.

11

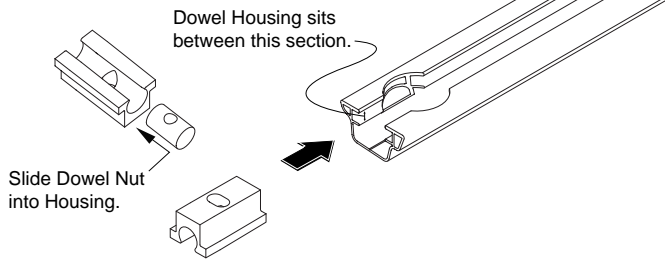

Slide the Legs into each end of the cross bar. Make sure the Channel Nut locates across the bar as shown. Only finger tighten the M10 Channel Nut bolt at this stage.

12

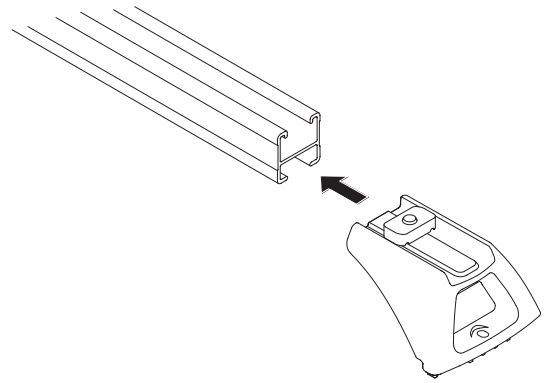

Finger tighten the Leg attachment bolt so that the Channel Nut turns to locate across the bar. The legs will require adjustment later.

13

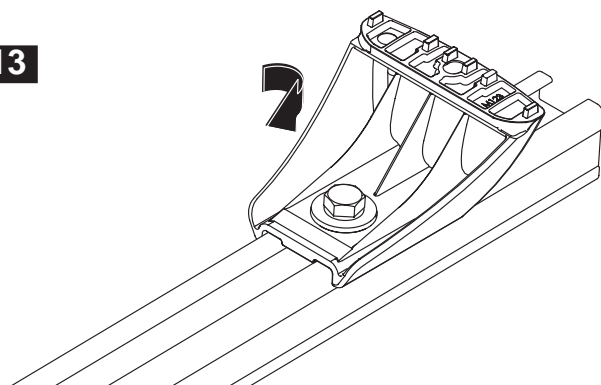

It is very important that the Channel Nut is fully located across the bar as shown.

14

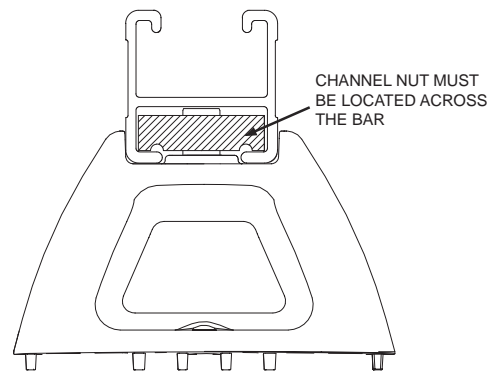

Place the Bottom Pad over the Dowel Nut Housing then Top Pad. Sit the Leg/Cross bar assembly on the Top Pad. Place the M6 Security Screw and washers through the hole in the Leg as shown and screw into the Dowel Nut. Slide Cross bar out of the way to better access the M6 Security Screw. Tightening torque is 3-4Nm. Tighten after positioning both sides equally.

15

Tangs face towards outside of vehicle

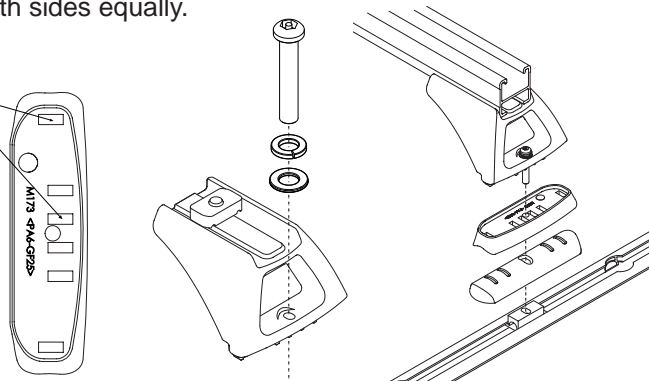

RCP Bottom Pad cannot be located over machined hole in track.

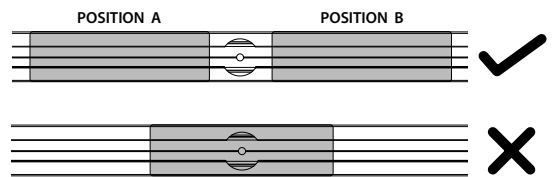

Tighten the cross bar attachment bolts. Recommended tightening torque (5Nm). Ensure that the channel nut is located across the cross bar.

16

DO NOT OVERTIGHTEN.

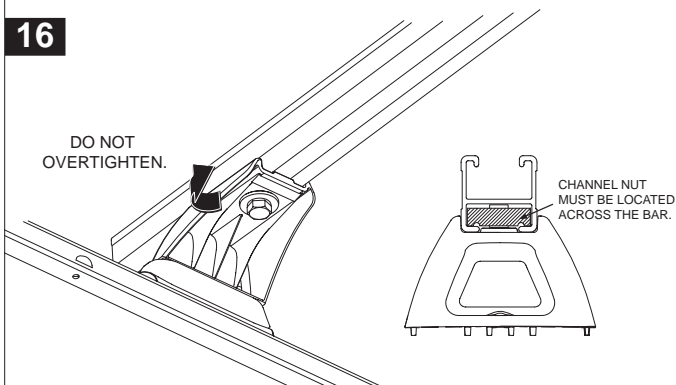

Prior to final fitment of the second cross bar/leg assembly, do a trial placement and measure the distance inbetween. Cut the rubber roof trim to this measurement. Slide the rubber roof trim into the Track as shown.

17

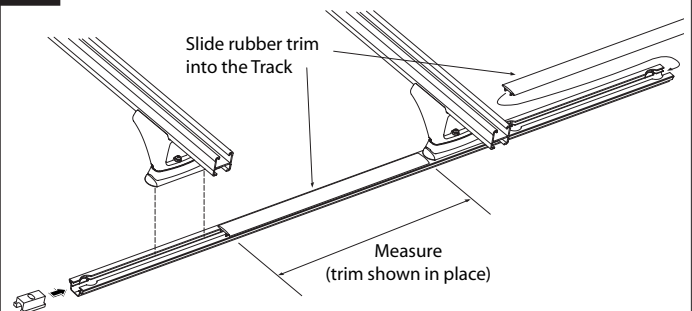

Measure and cut the rubber roof trim and put back in the vehicle roof channel at the front and rear ends of the Track. The front piece needs to be measured so the end of it sits under the windscreen rubber. The measurement and cutting of the rubber roof trim isn't critical since the End Cap will cover it. Recommend using a fine tooth hacksaw because of metal inside the rubber roof trim.

18

Cut trim 5-10mm from end of Track.

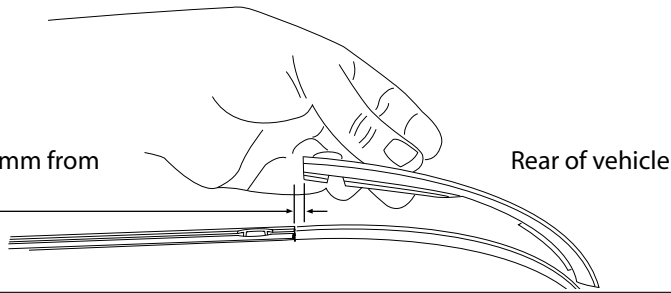

Showing the orientation of the end caps after installation. Caps are LEFT and RIGHT handed..

19

FRONT VIEW



With the leg/cross bar units tight and fixed in place the rubber roof trim can be cut and slid in place to cover the exposed areas of the Track at each end. The end cap is designed to sit over the rubber roof trim after it is cut. Therefore there is a generous tolerance on the measurement of the rubber roof trim.

20

Step 2.
Clip End Cap into the Track to cover end of trim.

Step 1.
Measure and cut the trim then slide into the track.

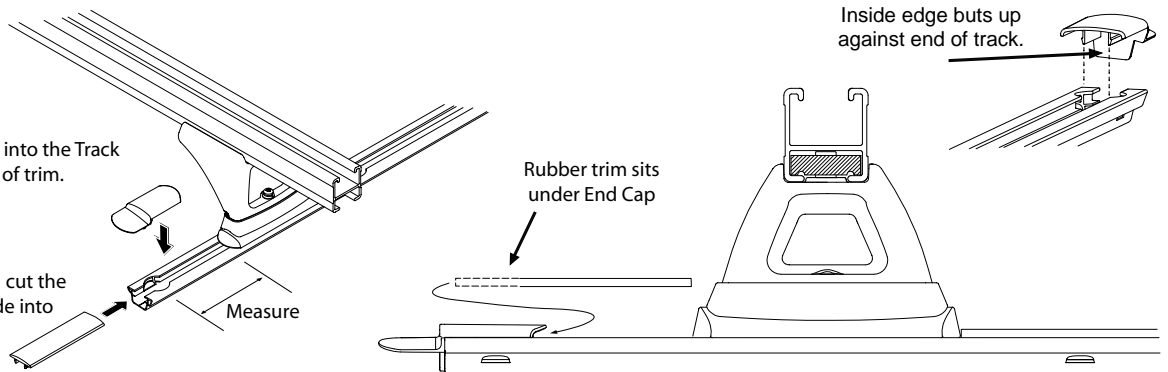

Check the cross bar over hang is equal on both sides, re-adjust if required.

21

EQUAL OVERHANG DISTANCE

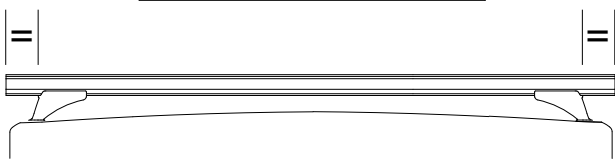

When front and rear cross bars are in required position, tension legs and cross bars.

22

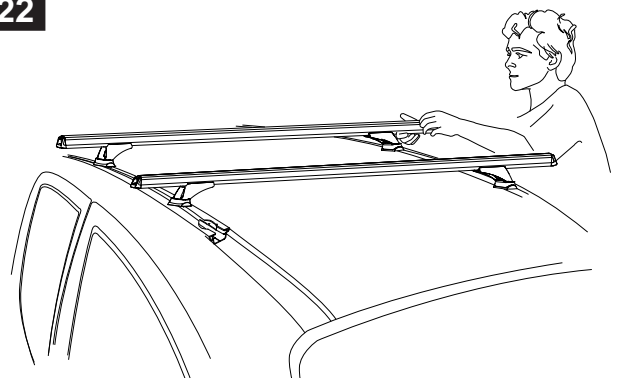

Insert the cross bar rubber buffer strip into the top of the cross bar. Insert the end caps into the ends of the cross bar, a rubber mallet may be required to fit the end caps.

23

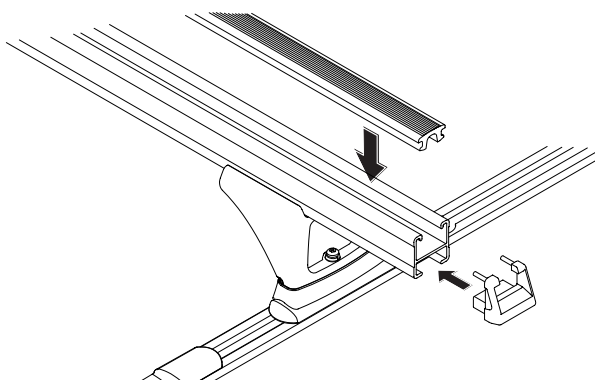

When the cross bars and legs are removed the roof pads can be covered for protection with the Mounting Pad Cover Plates.

24

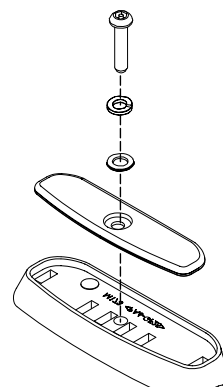

Important Information

Maximum carrying capacity: 100kg

Recommendations.

It is essential that all bolt connections be checked after driving a short distance when you first install your cross bars.

Bolt connections should be checked again at regular intervals (probably once a week is enough, depending on road conditions, usage, loads and distances travelled). You should also check the cross bars each time they are refitted.

Make sure to fasten your load securely. Please ensure that all loads are evenly distributed and that the centre of gravity is kept as low as possible.

Use only non-stretch fastening ropes or straps.

Sensitivity to cross winds, behaviour in curves and braking.

The handling characteristics of the vehicle, changes when you transport a load on the roof. For safety reasons, we recommend you exercise extreme care when transporting wind-resisting loads; special consideration must be taken into account when braking.

Please remove cross bars when putting vehicle through an automatic car wash.

Load Ratings.

Maximum permissible load is 100kg per pair of cross bars (include the weight of the cross bars, 5kg). When roof racks are to be used in off-road conditions, please build a safety factor of 1.5 into this load limit. Although the cross bars are tested and approved to AS1235-2000, Australian road conditions can be much more rigorous. However, increasing the number of cross bars does not increase the vehicles maximum permissible roof loading.

Note for Dealers and Fitters.

It is your responsibility to ensure instructions are given to the end user or client

Rhino-Rack
3 Pike Street, Rydalmere,
NSW 2116, Australia.
(Ph) (02) 9638 4744
(Fax) (02) 9638 4822

Document No: RR-131
Prepared By: Craig Jones
Authorised By: Gary England

Issue No: 03
Issue Date: 09/11/2009

These instructions remain the property of Fetovu Pty Ltd T/as Rhino-Rack and may not be used or changed for any other purpose than intended.