

WARNING! Important Load Carrying Instructions

With utility vehicles, the cabin and the canopy move independently. Roof racks and vehicle can be damaged if the item transported is rigidly fixed at points on both the cabin and canopy. Instead, rigidly fix to either the cabin roof racks or the canopy roof racks.

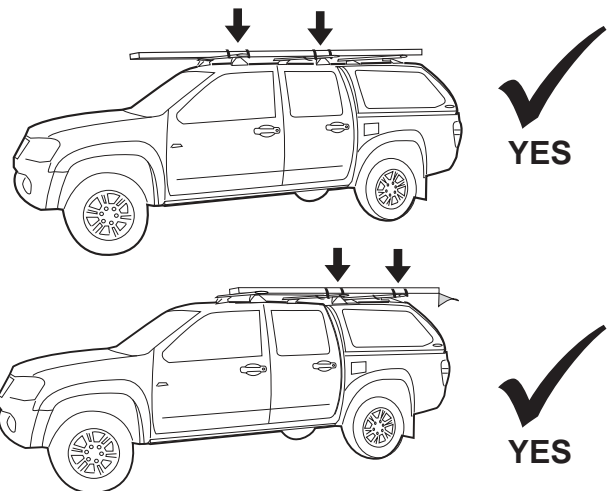

- Please refer to your vehicle manufacturers handbook for maximum roof load capacity.
- Any load transported on Roof Racks must be evenly distributed.
- Instructions are to remain with the vehicle.
- Do not attempt to fit the roof racks to your vehicle unless you fully read and understand the fitting instructions provided.
- Please direct any questions to the dealer from where the roof racks were purchased.

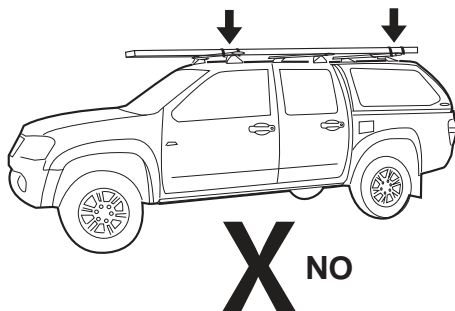

RHINO-RACK

RLT500 - Rhino Track Leg Kit

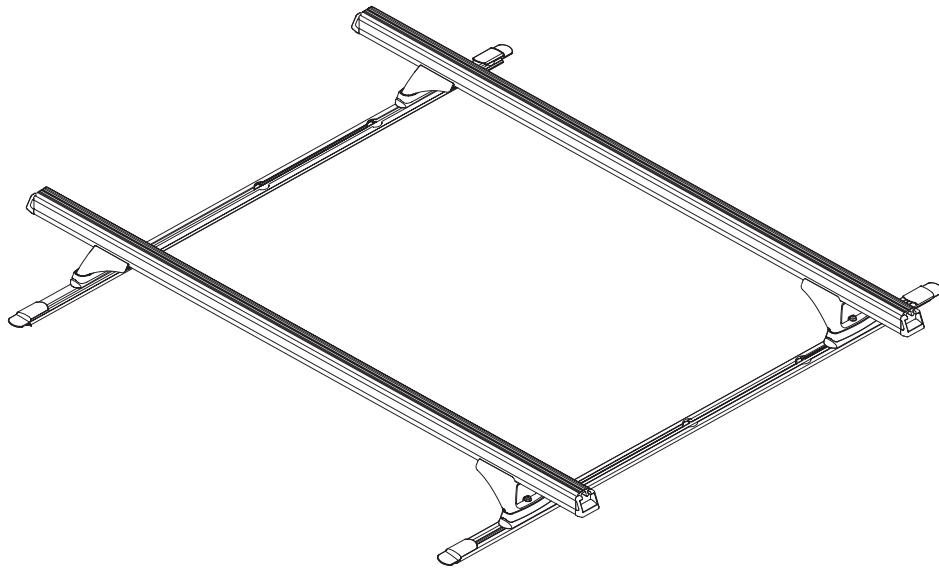

Important Information

Maximum carrying capacity: 100kg/220lbs evenly distributed over the crossbars. Please refer to your vehicle manufacturers handbook for maximum roof loading. Always use lower of these two figures.

Recommendations:

It is essential that all bolt connections be checked after driving a short distance when you first install your crossbars. Bolt connections should be checked again at regular intervals (probably once a week is enough, depending on road conditions, usage, loads and distances travelled). You should also check the crossbars each time they are refitted. Make sure to fasten your load securely. Please ensure that all loads are evenly distributed and that the centre of gravity is kept as low as possible.

Use only non-stretch fastening ropes or straps.

Caution: The handling characteristics of the vehicle changes when you transport a load on the roof. For safety reasons we recommend you exercise extreme care when transporting wind-resistant loads. Special consideration must be taken into account when cornering and braking.

Please remove crossbars when putting vehicle through an automatic car wash.

Load Ratings:

Maximum permissible load is 100kg/220lbs per pair of cross bars (include the weight of the cross bars, 5kg/11lbs). When crossbars are to be used in off-road conditions, please build a safety factor of 1.5 into this load limit, 66kg/145lbs for off-road use. Although the roof racks are tested and approved to AS1235-2000, off-road road conditions can be much more rigorous. However, increasing the number of crossbars does not increase the vehicles maximum permissible roof loading.

Note for Dealers and Fitters:

It is your responsibility to ensure instructions are given to the end user or client.

Rhino-Rack
3 Pike Street, Rydalmere,
NSW 2116, Australia.
(Ph) (02) 9638 4744
(Fax) (02) 9638 4822

Document No: R038
Prepared By: Craig Jones
Authorised By: Chris Murty

Issue No: 03
Issue Date: 28/03/2012

These instructions remain the property of Rhino-Rack Pty Ltd and may not be used or changed for any other purpose than intended.



RLT500

Parts List

Item	Component Name	Qty	Part No.
1	End Cap	2	M002
2	M6 x 40mm security screw	2	B085
3	Aero bar adaptor	2	M155
4	M6 spring washer	2	W004
5	M6 x 12.5mm flat washer	2	W003
6	RLCP Leg	2	M123
7	M10 channel nut	2	N024
8	Top Pad	2	M173
9	M10 x 38mm flat washer	2	W022
10	Base Pad	2	M172
11	M10 shakeproof washer	2	W021
12	M10 x 20mm hex bolt	2	B003
13	Dowel nut housing	2	A341
14	M6 x 16 Dowel Nut	2	N027
15	Pad cover plate	2	M126
16	5mm security allen key	1	H021
17	M6 brass spigot nut	2	N042K
18	M6 rectangular nut (foam back)	2	N035A
19	M6 brass hex nut	2	N036
20	Fitting instruction	1	R038

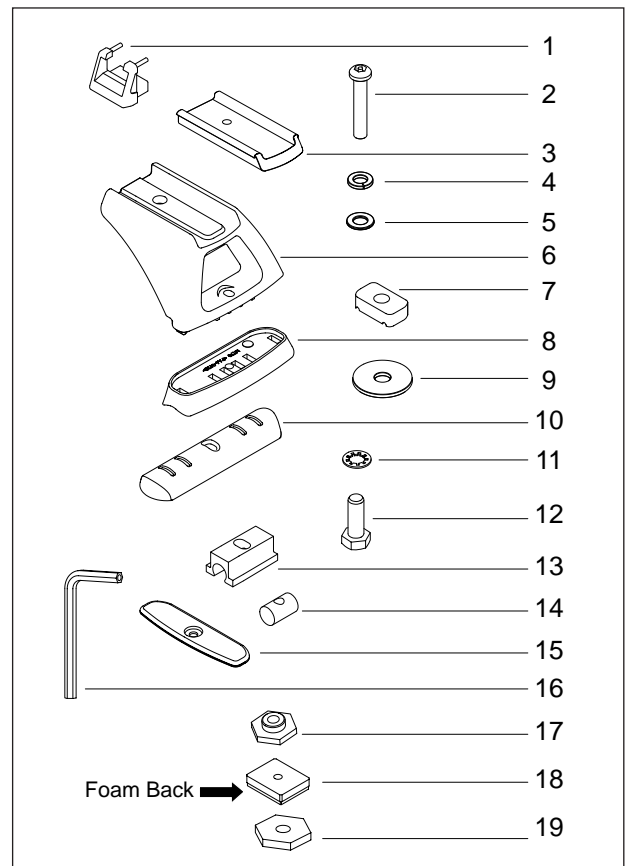

Tools Required:

5mm Security allen key, provided in kit.
5/8 or 16mm spanner.

Measuring tape.

Refer pages 4-6 for your particular vehicle.

Refer pages 6-8 for crossbar and leg assembly.

VOLKSWAGEN T5.....	page 4
CHEVROLET Trailblazer LS Sport Utility	page 4
CHEVROLET Trailblazer LS Extended Sport Utility	page 4
LAND ROVER Discovery 3	page 5
LAND ROVER Discovery 4	page 5
LAND ROVER LR3.....	page 5
LAND ROVER LR4.....	page 5
FORD Expedition.....	page 6
FORD Excursion.....	page 6



RLT500

VOLKSWAGEN T5

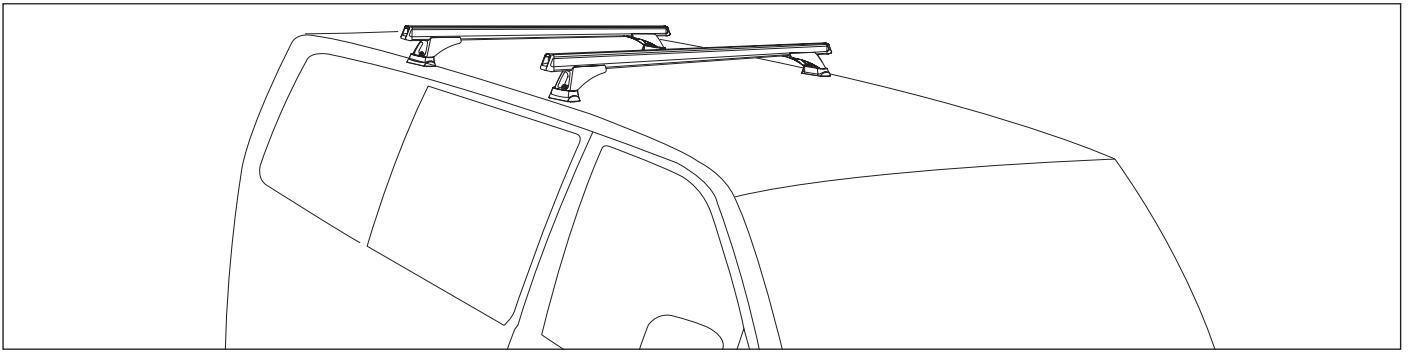

- 1** Place M6 Brass Hex Spigot Nut (item 17) into the opening of each track at rear of vehicle. Spigot facing up. Slide along the track to position.

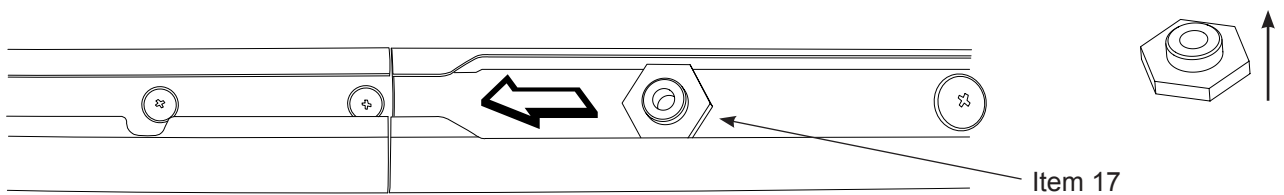

- 2** Spigot Nuts must **NOT** lay under a cutout in the track.

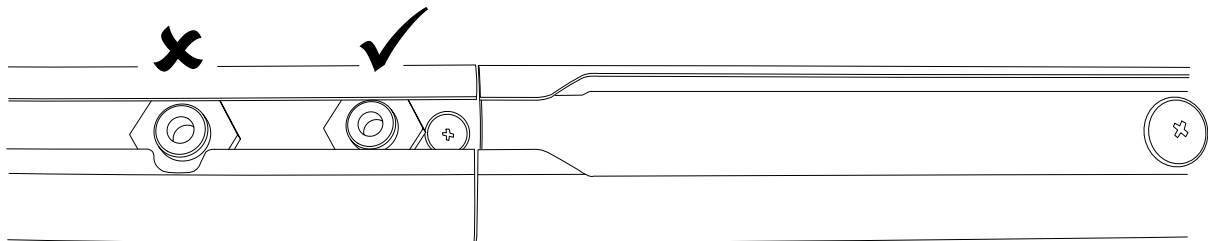

CHEVROLET Trailblazer LS Sport Utility CHEVROLET LS Extended Sport Utility

- 1**
- Carefully lift cover to unclip from roof rail track.
 - Depress side clips.

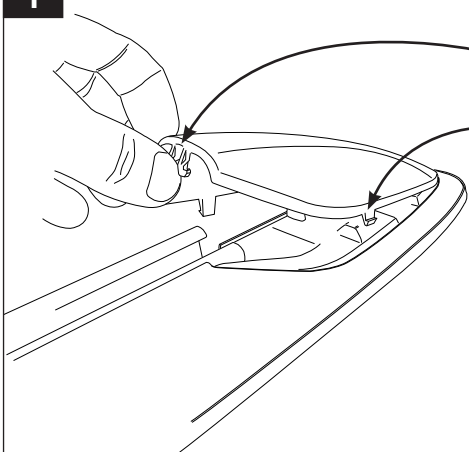

- 2** Slide dowel nut & housing into track. Clip plastic cover back in place.

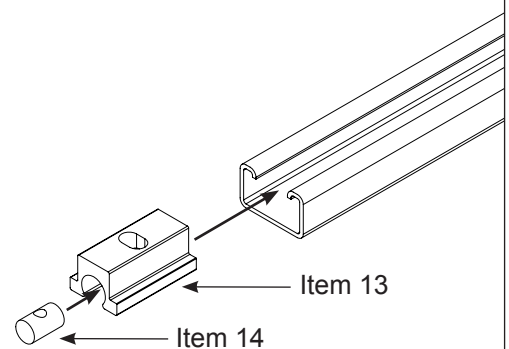



RLT500

LAND ROVER Discovery 3 & 4

LAND ROVER LR3 & LR4

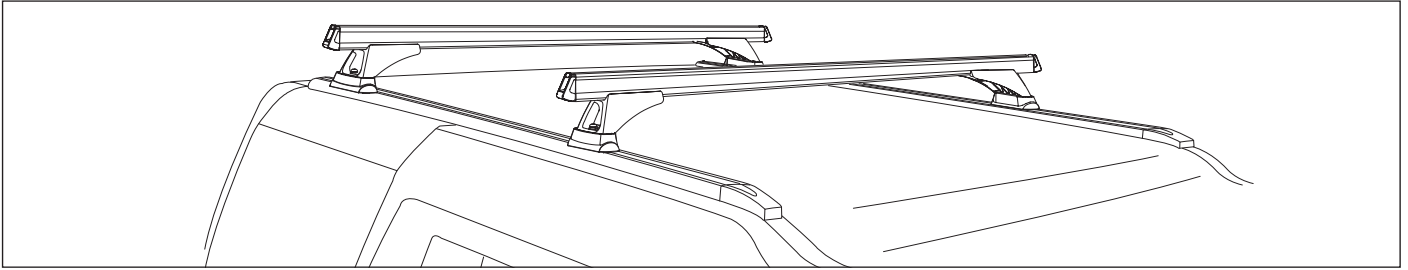

- 1** Foam pad of item 18 faces downward. Place two M6 rectangular foam backed nuts into each track. Push down on the nut and slide.

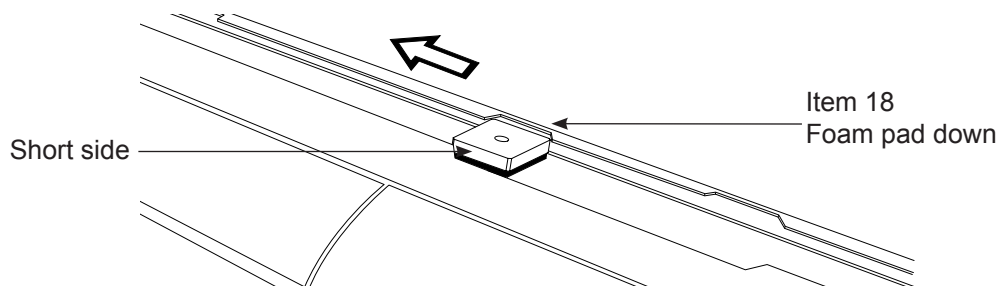

- 2** Position the M6 rectangular nuts so they are **NOT** lying in a cutout on the track.

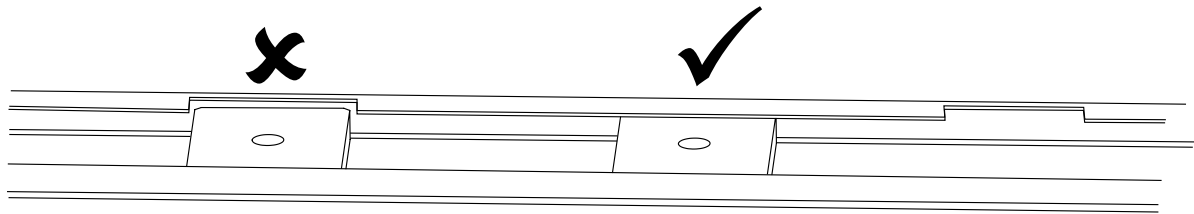

- 3** Place RLCP pads on factory track at measurements shown. The M6 rectangular must be fully located in the track and **NOT** under a cutout.

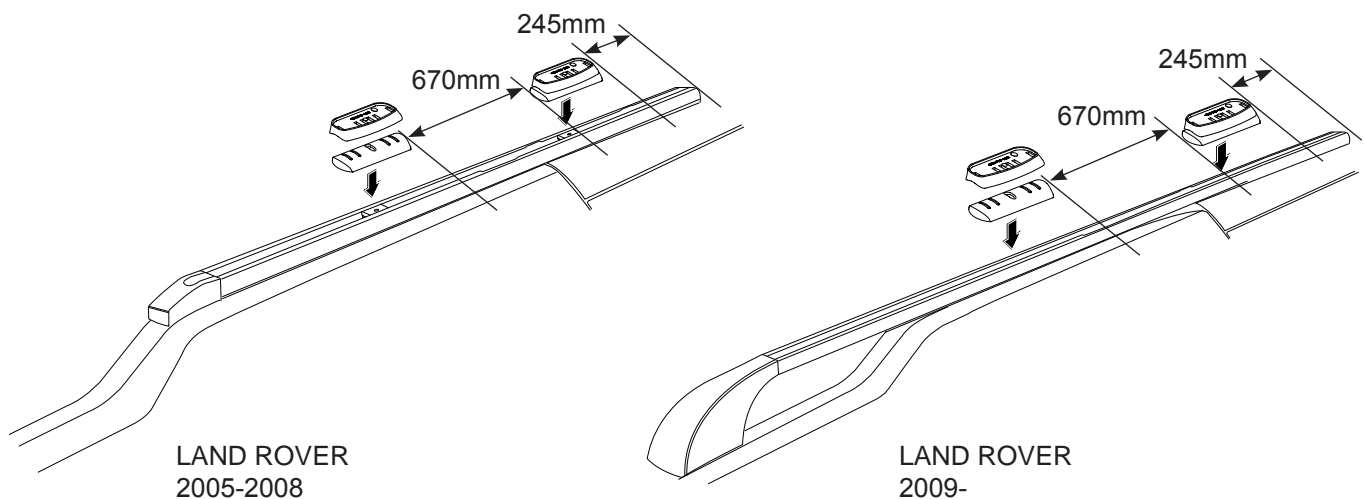



RLT500

FORD Expedition FORD Excursion

1 Depress end cap tab to enable dowel nut housing to slide into track.

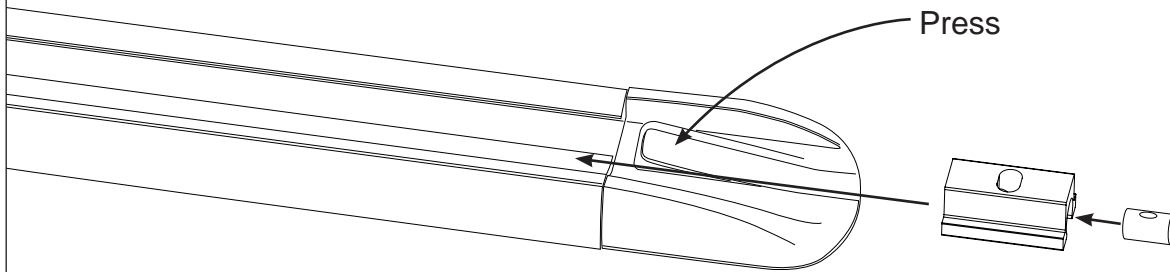

Following steps show how to attach legs and crossbars to the track.

1 Attach the legs to track using supplied screws and washers. Finger tighten only at this stage.

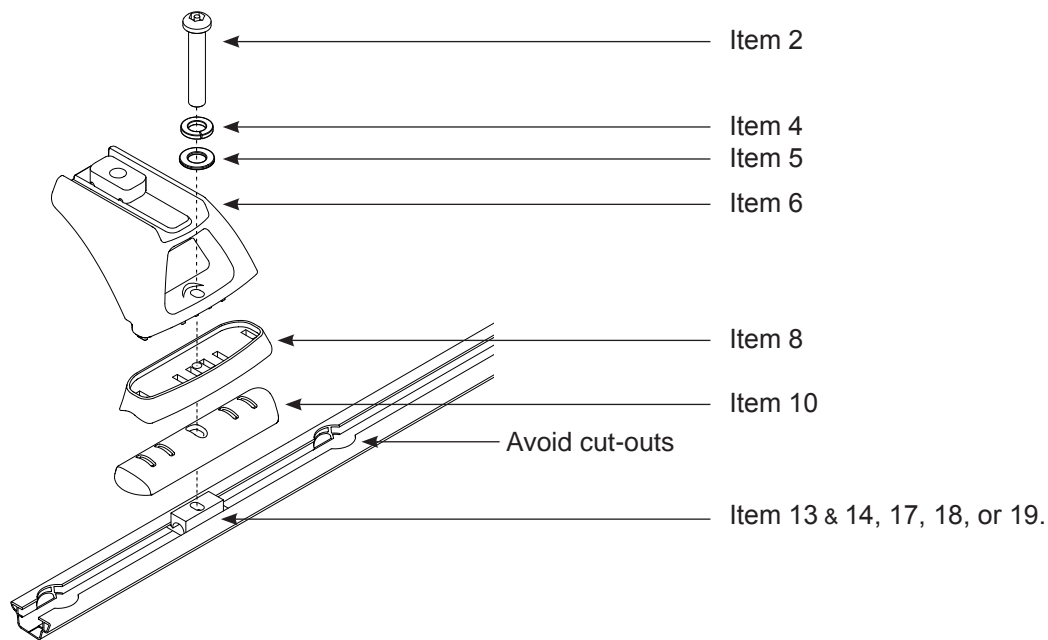

2

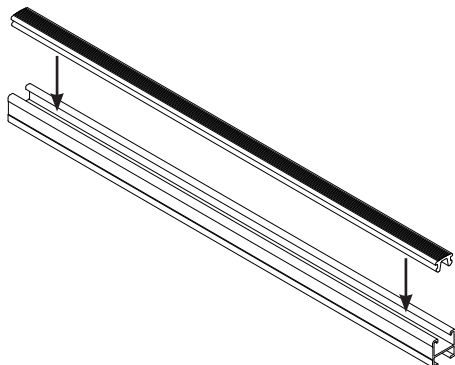

Insert crossbar rubber.



RLT500

3

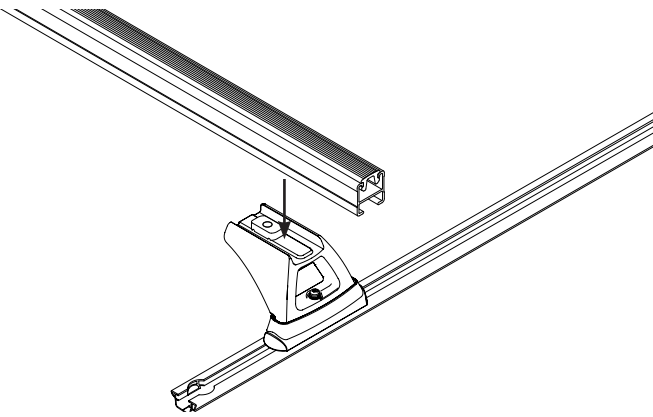

Attach crossbar.

Channel nut must fully locate across the bar.

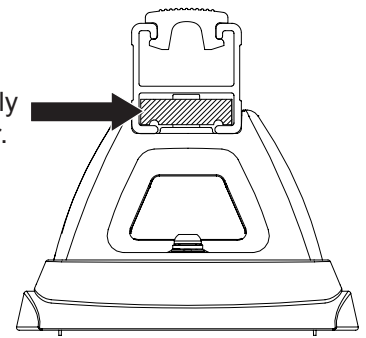

4

Adjust crossbar overhang to be equal both sides.

- a. Tighten M10 crossbar bolts to 11-12 Nm (8-9lb/ft).
- b. Tighten M6 security screws to 3-4 Nm (2-3 lb/ft).

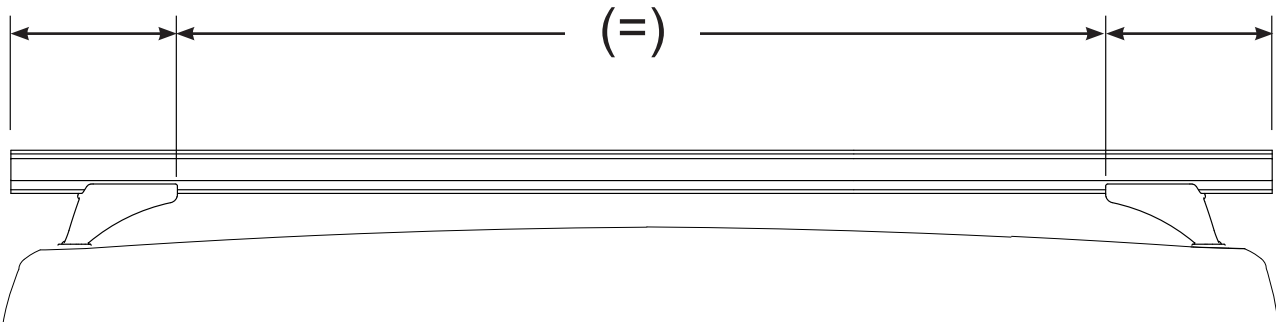

5

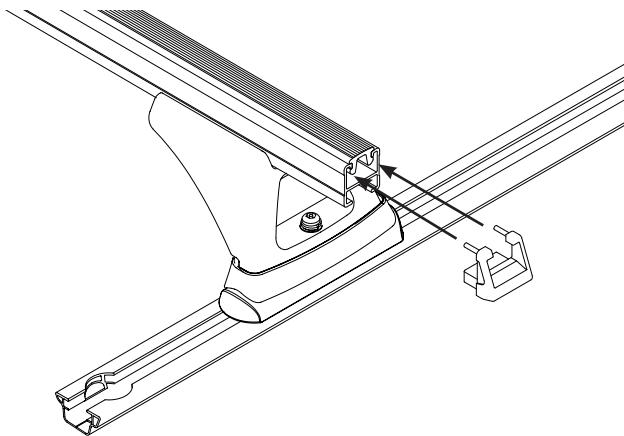

Fit end caps.

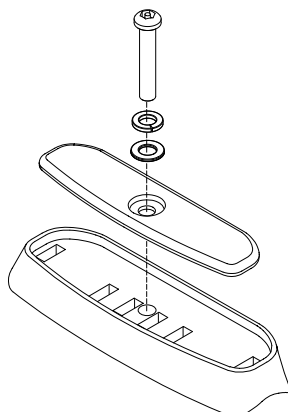

Pad cover plates are provided for when crossbars are removed.